

Operating manual

Material Collection System

CLS-G/H 1050, 1350, 1650



Carefully read chapter 4 Delivery and transport all the way through before unpacking the implement.

Prior to using the implement for the first time read this operating manual carefully and conscientiously all the way through.

Keep this manual where it is easily accessible. This will enable you to refer to important information and handling instructions as needed.

The operating manual is part of the implement. The operating manual must always be provided with new and used machines.

Introduction

1 Introduction

Dear customer! Dear customer!

Thank you for purchasing a product of matev GmbH, we appreciate your trust. You have acquired a quality product, if contrary to expectations you should have problems with the implement, contact your responsible sales partner.

Company stamp – sales partner



Prior to first use please read this operating manual carefully and conscientiously all the way through. The manual describes the handling of the implement and will support you in working safely and effectively, however it cannot substitute detailed instruction concerning the implement. By complying with the maintenance tasks you will retain the value and operational capability of the implement.

For damage that occurs due to operating errors or improper use, we will not accept any guarantee claims.

Variants may be described in the manual that do not agree with the scope of delivery of your implement.

Please enter the data of the rating plate on the implement in the manual. This information will be helpful in communication if there is a service case.



matev GmbH
90579 Langenzenn

Modell:

Code Nr.:

Fabr. Nr.:

Baujahr:

Ges.Gew.:

CE

The implement is subject to change in the interest of technical progress. All information, illustrations, and technical specifications represent the latest status at the time this manual was published. The manufacturer reserves the right to make changes at any time in the interest of technical progress.

Regards

matev GmbH

Table of contents

| | | |
|-----------|--|-----------|
| 1 | Introduction | 2 |
| 2 | About this operating manual | 4 |
| 3 | Safety | 5 |
| 3.1 | Intended use | 5 |
| 3.2 | Instructions for the owner | 5 |
| 3.2.1 | Instruction | 5 |
| 3.2.2 | Qualifications of personnel | 5 |
| 3.2.3 | Accident prevention | 5 |
| 3.3 | General safety notices | 5 |
| 3.4 | Warnings on the machine | 6 |
| 4 | Delivery and transport | 8 |
| 4.1 | Delivery on a pallet | 8 |
| 4.1.1 | Lift the implement off of the pallet | 8 |
| 4.1.2 | Long-distance transport | 8 |
| 4.2 | Transport over short distances | 8 |
| 5 | Operation | 9 |
| 5.1 | Intended use | 9 |
| 5.2 | Mounting on the rear three-point linkage of the tractor | 9 |
| 5.3 | Detaching the material collection system from the rear three-point linkage | 11 |
| 5.4 | Mounting and adjusting the universal joint shaft | 11 |
| 5.5 | Mounting the suction port and suction hose | 12 |
| 5.6 | Starting and switching off the turbine | 13 |
| 5.7 | Lifting, lowering, and emptying the collection container | 14 |
| 5.7.1 | Low-dump | 14 |
| 5.7.2 | High-dump | 15 |
| 5.8 | Clean the filter mat | 16 |
| 6 | Maintenance | 18 |
| 6.1 | Service schedule (overview) | 18 |
| 6.2 | Lubricating schedule | 19 |
| 6.3 | Adjustment tasks | 21 |
| 6.4 | Troubleshooting | 23 |
| 7 | Repair | 25 |
| 8 | Disposal | 25 |
| 9 | Guarantee | 25 |
| 10 | Technical data | 25 |
| 11 | List of illustrations | 26 |
| 12 | EC - Declaration of Conformity | 27 |

2 About this operating manual

Prior to first use read this operating manual carefully and conscientiously all the way through.

Keep this operating manual where it is easily accessible. This will enable you to refer to important information and handling instructions as needed.

At transfer of the machine the owner of the machine receives instruction in the operation and maintenance of the machine from the owner's sales partner.

The owner must ensure that operating and maintenance personnel have been instructed in full scope in the operation and maintenance of the machine.

Listings with bullet points are marked as follows:

- Text
- Text
- Text

Handling instructions are marked in the sequence in which they should be executed, as follows:

1. Text
2. Text
3. Text. . .

3 Safety

Guidelines and instructions with which you must comply, are summarized in this section.

3.1 Intended use

The implement must only be used in accordance with its specifications. Please read **chapter 5.1 Intended use** all the way through. All other uses are excluded.

Non-intended use causes:

- Health hazards for the operator or for third parties
- Implement damage
- Environmental damage

3.2 Instructions for the owner

3.2.1 Instruction

At transfer of the machine the owner of the machine receives instruction in the operation and maintenance of the machine from the owner's sales partner.

The owner must ensure that operating and maintenance personnel have been instructed in full scope in the operation and maintenance of the machine.

3.2.2 Qualifications of personnel

This machine must only be operated by persons who are qualified, as follows:

- They must be at least 18 years old.
- They have received instruction on the machine.
- They must have read and understood this operating manual.
- They have been instructed concerning the relevant safety regulations (accident prevention).

The relevant accident prevention regulations and the other generally acknowledged occupational health and safety and road traffic regulations must be complied with at all times.

3.2.3 Accident prevention

The safety regulations and accident prevention regulations are legally regulated in every country. The owner of the machine is responsible for compliance with the valid regulations.

3.3 General safety notices

In this section general safety notices/instructions are explained that are used in the subsequent sections.

Comply with these safety instructions to ensure safe operation and to save work time and costs.



Danger!

Severe injury to the operator or third parties occurs.

Comply with the safety notice.



Attention!

Minor injury to the operator or third parties can occur. The tractor, the implement, or the environment can be damaged.

Comply with the safety notice.



Note!

Important, helpful tips or information for the operator. Read this note. It facilitates your work.



Attention!

Injuries can occur.

Wear protective work clothing.

3.4

Warnings on the machine

Warnings and their general meaning are specified below that are also affixed as stickers on the implements.



Attention!

Danger of injury due to moving parts.

Remove the ignition key before performing tasks on the implement.



Danger of injury due to rotating parts.

Maintain a safe distance from the area of drive shafts.

Switch off the implement. Wait until all machine parts have come to a standstill before performing tasks on the implement.



Attention!

Injuries can occur due to improper operation. The implement can be damaged.

Read the operating manual all the way through.

Comply with the safety instructions.



Attention!

Injuries due to fluid escaping under high pressure.

Comply with the notice in the operating manual.



Attention!

Danger of crushing due to moving parts.

Never reach into the crushing hazard danger zone if parts are moving or can move.

Comply with the notice in the operating manual.



Attention!
Danger of injury due to the hydraulic system.
Do not enter the danger zone unless the lift cylinder safeguard is in place.

4 Delivery and transport

Our implements are delivered in suitable packaging. Please comply with the valid occupational health and safety regulations when unpacking and use suitable hoists if necessary.

4.1 Delivery on a pallet

4.1.1 Lift the implement off of the pallet

1. Remove the protective packaging and the transport safeguard.
2. Lift the implement off of the pallet with a suitable device (crane or forklift) and set it down.

4.1.2 Long-distance transport

If you want to transport the implement over longer distances (e.g. shipping via freight forwarder), you must lash the implement onto a pallet.



The implement must only be transported in empty status without tractor!

Do not unhook the material collection implement from the tractor in filled status.

4.2 Transport over short distances

- If the implement is not attached on a tractor, it must only be transported in empty status.
- Suitable transport equipment or hoists must be used (crane, forklift, lift truck)

We offer wheel sets for many of our implements that enable safety and convenient transport over short distances.



Please contact your sales partner for additional information

5 Operation



Danger!

At transfer of the machine the owner of the machine receives instruction in the operation and maintenance of the machine from the owner's sales partner. The owner must ensure that operating and maintenance personnel have been instructed in full scope in the operation and maintenance of the machine. The machine must not be operated or maintained without instruction.

Due to the variety of towing vehicles and variants of our implements, only the fundamentals of operation can be described here. At transfer of the machine you will receive instruction on your machine from your sales partner.

5.1 Intended use

The material collection system should only be mounted on tractors with sufficient power. The material collection system must only be used in conjunction with a mower or a leaf vacuum nozzles with the connection intended for this purpose. It is used for collecting cuttings and leaves.

The speed of the rear PTO shaft must agree with the speed on the material collection system (see the sticker on the material collection system in this regard).

The prescribed ballast for the tractor and the specified maximum axle load must be complied with.

All other uses are excluded.

Non-intended use causes:

- Health hazards for the operator or for third parties
- Damage to the front mower and the implements
- Environmental damage

5.2 Mounting on the rear three-point linkage of the tractor



Danger!

If you do not comply with the following instructions, the implement can tip over when it is being attached:

Place the material collection implement on a level and solid substrate.

Only attach the material collection system if the collection container is empty, closed and lowered.

Operation

Proceed as follows to attach the material collection system on a rear three-point linkage:

1. Turn the casters to the rear and secure them with the arrest bolts.

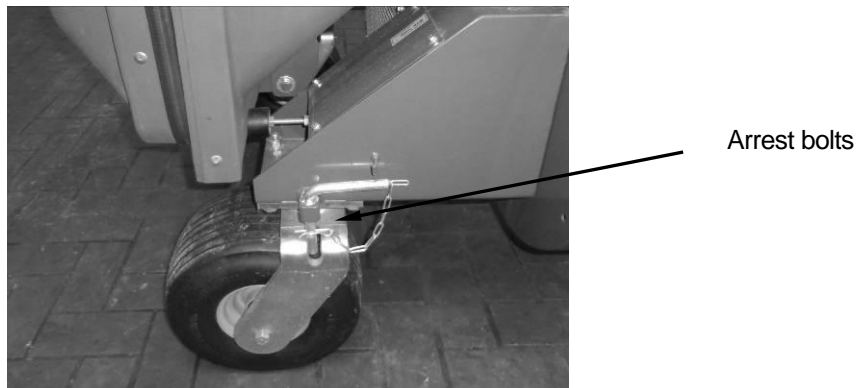

Fig. 1: Arrest bolts

2. Drive the vehicle in reverse close to the material collection system.
3. Remove the linch pin on the lower link bolt
4. Remove the top link bolt
5. Adjust the height of the rear three-point linkage via the lower link bolts of the material collection system.
6. Hook-in the lower link on the material collection implement and secure the lower link with the linch pins

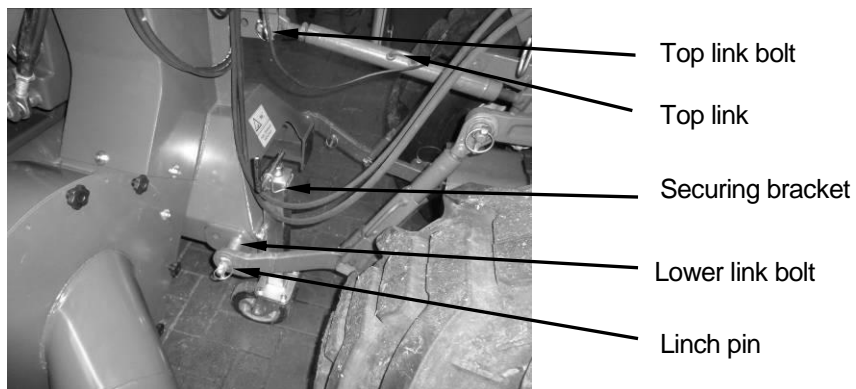

Fig. 2: Lower link bolt

7. Hook-in the top link and secure the top link bolt with the linch pin.
8. With the aid of the top link, align the implement so that the shell is vertical.



Fig. 3: Align the implement

9. Crank the support wheel upward and secure it with the bracket.
10. Connect the hydraulic connections of the material collection system to the connections on the tractor.

11. If your grass collection implement has an electric changeover valve, connect the plug to the towing vehicle.
12. Mount the universal shaft as shown as described in chapter 5.4.

5.3 Detaching the material collection system from the rear three-point linkage



Danger!

If you do not comply with the following instructions the implement can tip over when it is being detached:

Place the material collection implement on a level and solid substrate. Only detach the material collection system if the collection container is empty, closed and lowered.

Proceed as follows to detach the implement from a three-point linkage:

1. Turn the casters to the rear and secure them with the arrest bolts (see Fig. 1: Arrest bolts)
2. Crank the support wheel downward and secure support wheel with the securing bracket (see Fig. 2: Lower link bolt)
3. Disconnect the hydraulic hose connections.
4. Unplug the plug connector from the tractor's power connection.
5. Uncouple the universal joint shaft from the tractor.
6. Unhook the lower link and top link.

5.4 Mounting and adjusting the universal joint shaft

Attention!



The universal joint shaft is especially adapted to the vehicle and the material collection system. At first use, always check, as described in this chapter, whether it has been adapted!

If not, adjust the universal joint shaft, as described in the original operating manual of the universal joint shaft, attention!



To prevent the PTO shaft brake from being damaged, we recommend a universal joint shaft with freewheel element.

To check whether the universal joint shaft is the correct length for your vehicle you must attach the material collection system on the three-point linkage. In this regard, proceed as described in **5.2 Mounting on the rear three-point linkage** of the tractor.

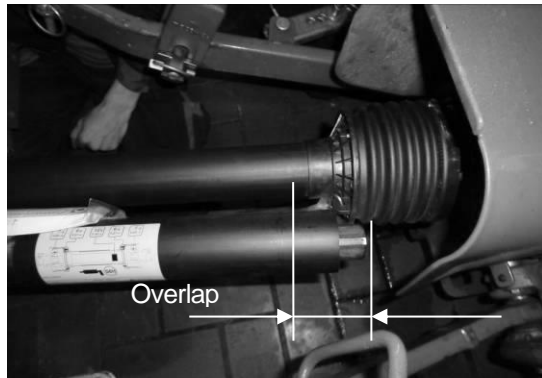

Fig. 4: Check universal joint shaft

The universal shaft in Fig. 4 is too long and must be shortened in accordance with the provided operating manual of the universal joint shaft.

5.5 Mounting the suction port and suction hose



Danger!

Severe injury to the operator or third parties occurs.

Switch off the tractor and remove the ignition key before working on the mower or on the turbine.



Attention!

If you dismount the suction port, mount the original discharge guard.

Never operate the mower without either the discharge guard or the suction port installed.



Note!

In addition to this manual also read the safety and operating instructions specified in the associated mower manual.

Turbine
Suction hose
Hose clamp
Port
Attachment parts for the port



Fig. 5: Mounting of the suction port and suction hose

1. Lower the mower.
2. Remove the ignition key.

3. Remove the original rock guard.
4. Mount the supplied suction port with the attachment parts on the mower. This mounting process will vary depending on the mower type.
5. Secure the connections.
6. Slide the suction hose onto the opening of the suction port and secure it with the hose clamp.
7. Slide the suction hose onto the opening on the turbine cover and secure the connection with the hose clamp.

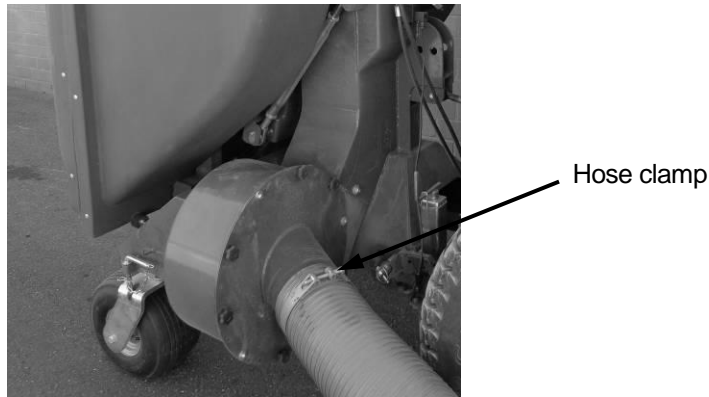

Fig. 6: Suction hose on the turbine

5.6 Starting and switching off the turbine

Danger!



Severe injuries occur due to the rotating turbine.

The turbine continues to rotate after it is switched off.

Wait until the turbine has come to a standstill before executing maintenance or conversion tasks. The afterrun times vary based on the tractor/implement combination.

The turbine's task is to take up the cuttings or leaves from the mower or leaf vacuum via the suction line and transport the cuttings or leaves into the container via the pressure line.

The process of switching the rear PTO shaft on and off varies depending on tractor type (see the tractor operating manual in this regard).

- Switching on the rear PTO shaft means: The turbine is running.
- Switching off the rear PTO shaft means: The turbine will come to a standstill.



Attention!

To avoid damage to the vehicle and grass collection implement, only switch the rear PTO shaft on and off at a slightly increased idle speed.



Attention!

To prevent the PTO shaft brake from being damaged, we recommend a universal joint shaft with freewheel element.

5.7 Lifting, lowering, and emptying the collection container



Danger!

Severe injury to the operator or third parties occurs.

Comply with the following instructions when lifting and lowering the collection container:

Ensure that no one is in the danger zone.

The material collection system can tilt. The tractor must be on a firm and level substrate when you empty the collection container.



Attention!

Always completely empty the grass container, before:

Driving on public roads

Uncoupling from the tractor

All maintenance tasks

On slopes only fill the implement 50%. Drive straight uphill or downhill, never drive transverse to the slope.



Attention!

Lifting the filled CLS implement with the rear three-point linkage does not correspond to intended use. If you want to lift the filled CLS implement off of the substrate with the rear three-point linkage, strictly comply with the axle loads, as well as lifting forces of the tractor. Depending on the condition of the cuttings and container type, the implement weight with filled container can be as much as 1070 kg (without accessories).

The procedures for emptying the CLS differ between low-dump and high-dump.

5.7.1 Low-dump



Danger!

Severe injury to the operator or third parties occurs.

Ensure that there is no one in the opening area.



Attention!

The implement can be damaged if material remains between the cover and the container.

The CLS is emptied from the driver seat via activation of the tractor's hydraulic system.

1. Approach the dump point with the tractor in reverse.
2. Activate the tractor's hydraulic system to close the cover.
The cuttings will drop out.
3. Drive forward.
4. Ensure that no material (grass or similar material) is between the cover and the container.



Fig. 7: Low-dump

5. Activate the tractor's hydraulic system to close the cover.
6. Ensure that the cover is tightly sealed, i.e. ensure that the cover rests flush on the container.

5.7.2 High-dump



Attention!
Danger of injury due to the hydraulic system.
If the container is lifted, do not enter the danger zone unless the lift cylinder safeguard is in place.

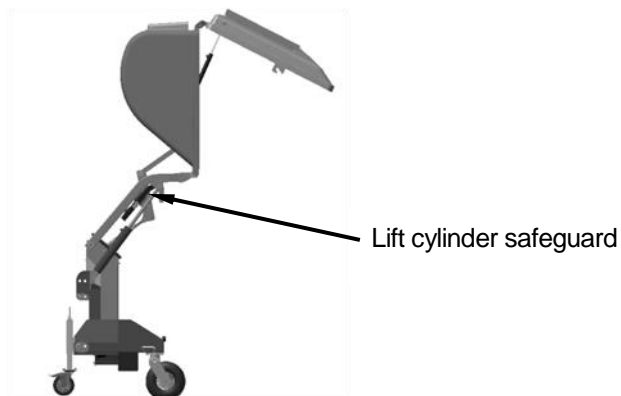

Fig. 8: Lift cylinder safeguard

The CLS is emptied from the driver seat via activation of the tractor's hydraulic system.

Proceed as follows to empty the high-dump collection container:

1. Approach the dump point with the tractor in reverse to 2 m in front of the dump point.
2. Lift the collection container. If the implement is lifted with the same hydraulic circuit, ensure the correct position of the switch for the changeover valve.
3. Activate the tractor's hydraulic system until the desired collection height is reached.



Fig. 9: Container lifted out, cover closed.

4. Approach the dump point with the tractor in reverse.
5. If your material collection system has an electromagnetic changeover valve, then set it on Open/Close cover.
6. Activate the tractor's hydraulic system to close the cover.
The cuttings will drop out.
7. Drive at least 2m forward.
8. Activate the tractor's hydraulic system until the cover is closed.
9. If your material collection system has an electromagnetic changeover valve, then set it on Lift/Lower container.
10. Activate the tractor's hydraulic system until the container is lowered.
11. Ensure that the cover is tightly sealed, i.e. ensure that the cover rests flush on the container and that the container is fully seated on the channel.

5.8 Clean the filter mat

The filter mat of the material collection system can be removed for easy cleaning.



Attention!

The material collection system must be completely emptied and in the lowered position.

Switch off the implement and remove the ignition key on the tractor.

1. Remove the spring cotter on the retaining rod of the filter mat



Spring cotter pin

Fig. 10: Spring cotter pin – filter mat

2. Pull the retaining rod to the right until the filter cloth is unlocked.



Fig. 11: Retaining rod – filter cloth

3. Pull the filter cloths downward and out of the guide



Fig. 12: Remove filter cloth

4. Clean the filter cloth
5. Slide filter cloth back into the guide.
6. Lock the filter cloth with the rod and secure the rod with the spring cotter.

6 Maintenance

Danger!

The implement can fall over.



Only perform service and maintenance tasks when

- the CLS is on level ground,
- the CS is mounted on the tractor and
- the collection container is empty.



Danger!

Severe injury to the operator or third parties occurs. Only perform service and maintenance tasks with lifted container, if the container has been safeguarded against falling unintentionally by appropriately positioning the lowering safeguard. Do not forget to unhook the lowering safeguard before lowering the container



Attention!

Properly reattach all protective devices that have been dismantled after executing the maintenance tasks.



Note!





- After the first 20 hours of operation check all screw and bolt connections.
- Subject the CLS to regular service.
- Only use lubricating grease, do not use oil to lubricate moving parts.

6.1 Service schedule (overview)

| Time interval | Activity |
|------------------------------------|---|
| After the first 20 operating hours | <ul style="list-style-type: none"> • Check all screw connections and bolt connections. Tighten any loose screws, and secure any loose bolt connections with spring cotter pins. |
| Daily or before each use | <ul style="list-style-type: none"> • Check the safety elements and moving parts for wear. Replace worn or defective parts, as needed • Check the hydraulic connections and lines for leaks. Replace leaking connections and lines, as needed. • For the chassis version, check the air pressure of the casters and adjust the air pressure if necessary. |
| After each use | <ul style="list-style-type: none"> • clean the entire implement. • Particularly clean the container, and in the container clean the perforated sheet, metal grille and the filter, the turbine, the suction hose, and the suction port from the inside. |

6.2 Lubricating schedule



Lubricating points are marked with stickers. If a sticker is on a cover that can be dismounted, then as a rule the lubricating nipple is under the cover.

| Symbol | Meaning |
|--|---|
| 1/d | Lubricate daily |
| 1/50h | Lubricate every 50 operating hours |
| 2/a (1/500h) | Lubricate at the beginning and end of the season and after 500 operating hours |
|  | Use a grease gun |
|  | Check oil level, top-up oil if necessary Please comply with the instructions in the provided operating manuals |
|  | Check oil level, top-up oil if necessary Change oil ever x years. Please comply with the instructions in the provided operating manuals |
|  | Please comply with the operating manual provided for this component. The lubricating intervals are specified in the operating manual |

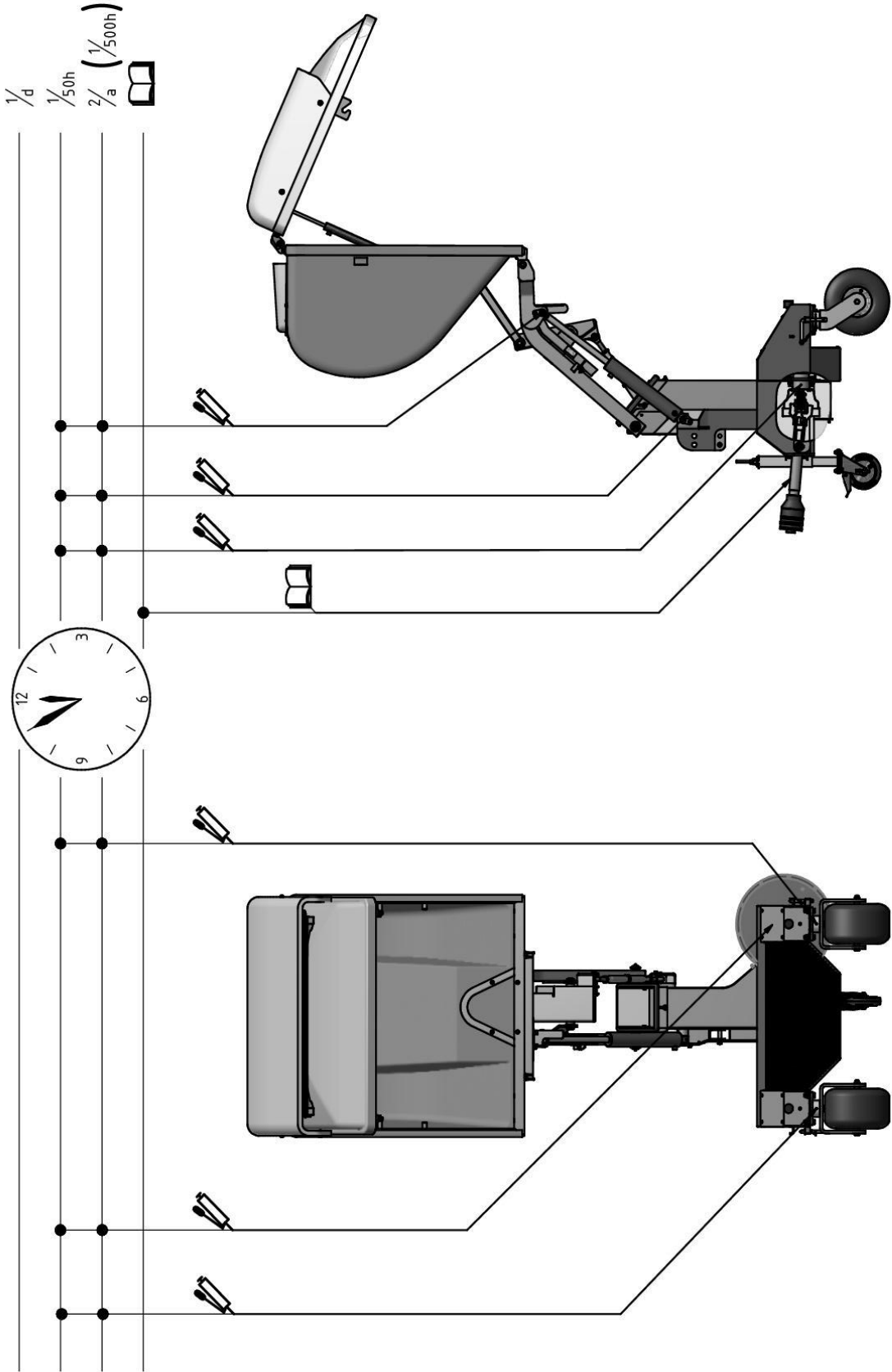
Maintenance

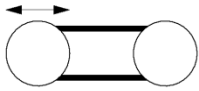
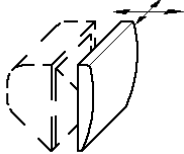
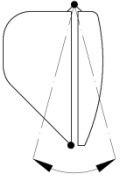
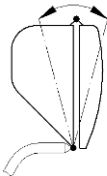

6.3 Adjustment tasks

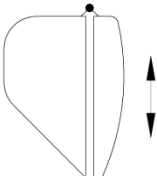
| Symbol | Meaning |
|---|--|
|  | <p>Adjust the belt tension on the adjustable bearing block</p> |
|  | <p>Adjust the distance and position of the rear shell to the front shell via adjustable hinges.</p> |
|  | <p>Adjust the closing angle of the rear shell through length change on the cylinder.</p> <p>If the rear shell has a locking mechanism, then this can be adjusted with the aid of the slotted holes in the strike plate.</p> |
|  | <p>Set the angle at which the collection container rests on the discharge chute, by changing the length of the top link.</p> <p>Shorten the top link -> implement tilts to the rear (away from the vehicle)</p> <p>Lengthen the top link -> implement tilts to front.</p> |
|  | <p>The horizontal position of the collection container relative to the infeed chute is adjusted by changing the length of the lift cylinder.</p> <p>For this the rubber buffers must be loosened and set to the shortest position. After the adjustment, the rubber buffers are unscrewed far enough that they rest on the lift are and then they are unscrewed another turn, and secured with the lock nut.</p> <p>Extend the cylinder -> collection container moves away from the towing vehicle.</p> <p>Shorten the cylinder -> collection container moves toward the towing vehicle.</p> |
|  | <p>The vertical position of the collection container relative to the infeed chute is adjusted on the infeed chute. The position of the collection container no longer changes through this adjustment.</p> <p>On the infeed chute the seal carrier can be slid via slotted holes.</p> |

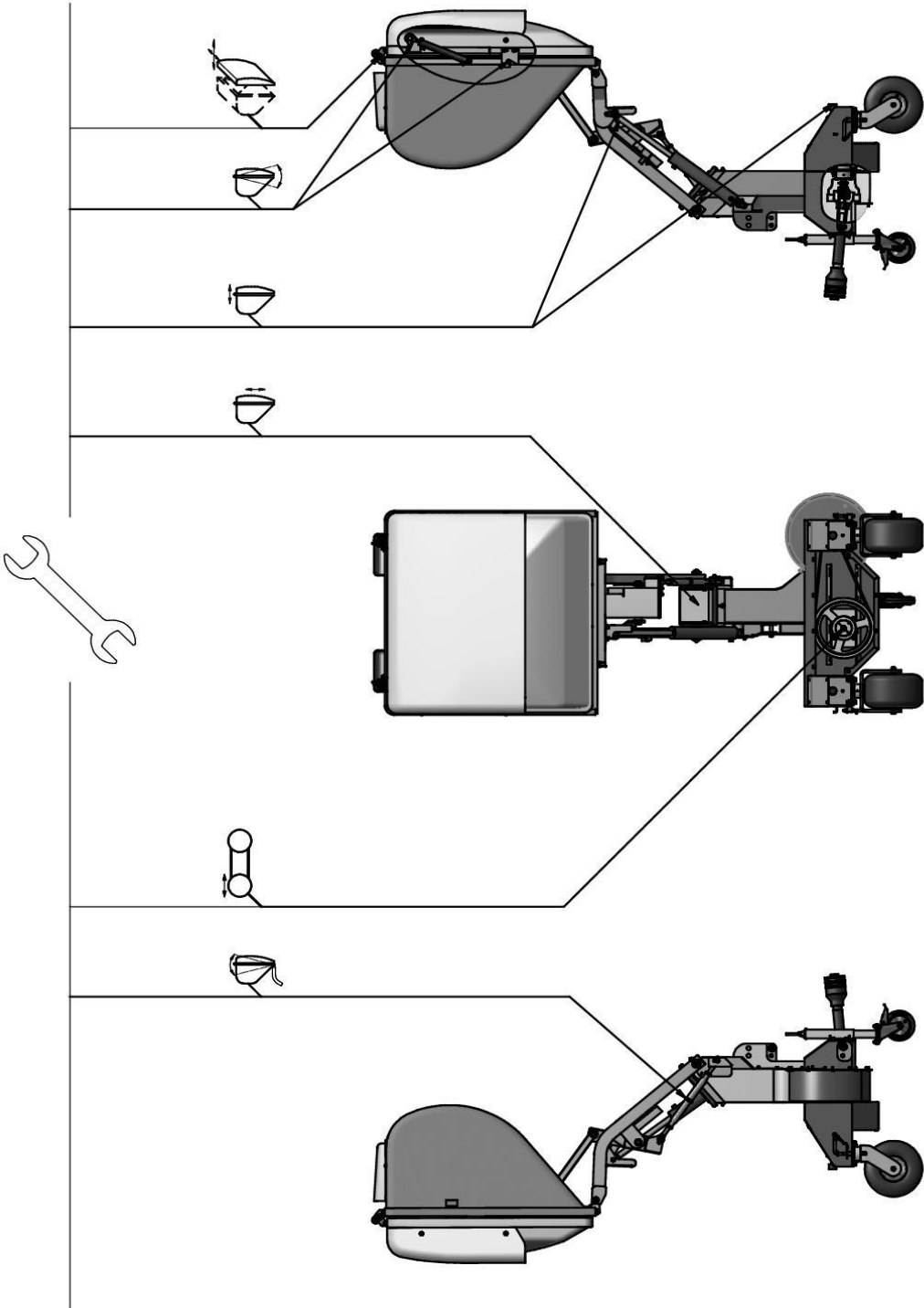

6.4 Troubleshooting

Danger!
Severe injury to the operator or third parties occurs.
Danger!



Comply with the following instructions when executing the troubleshooting tasks cited below:

- You must switch off the tractor and remove the ignition key.
- You must safeguard the collection container against lowering unintentionally, please use the lowering safeguard on the lift cylinder.
- You must safeguard the cover of the collection container against lowering unintentionally.

| Fault | Possible cause / correction |
|--|--|
| Suction port blocked | <p>Possible cause</p> <ul style="list-style-type: none"> • Driving too fast for the given conditions. <p>Remedy</p> <ul style="list-style-type: none"> • Drive more slowly. |
| Suction hose or turbine channel is blocked | <p>Possible cause</p> <p>Grass has accumulated due to a branch lodged in a transverse position or due to a larger object or the container is already full.</p> <p>Remedy</p> <ul style="list-style-type: none"> • Turn off the implement and engine. • Use a tool to remove the hose. • Clean the hose. • Fasten the hose. • Use a tool to take off the turbine cover, clean turbine. • Lift out the container and secure it with the lowering safeguard. Clean the infeed chute and turbine. |
| Poor suction capacity | <p>Possible causes</p> <ul style="list-style-type: none"> • The exhaust grille or the filter is blocked. • Mower is adjusted too low. <p>Remedy</p> <ul style="list-style-type: none"> • Clean the exhaust grille or the filter. • Adjust the mower so that it is higher. |
| Strong vibration when the blower is running | <p>Possible cause</p> <ul style="list-style-type: none"> • Fan blade is out of balance. <p>Remedy</p> <ul style="list-style-type: none"> • Turn off the implement and engine. • Take off the blower cover and check the blades. • Clean the blades if there is heavy fouling. • Mount the cover and hose properly. • Perform a trial run. <p>ATTENTION!</p> <p>Never run the mower without cover and hose!</p> <p>If the cause of the vibration cannot be rectified, or if the blade is damaged, the implement must be repaired in an authorized service center</p> <p>The blade must be balanced. Never use an unbalanced blade!</p> |
| The hydraulic system for the container does not function | <p>Possible causes</p> <ul style="list-style-type: none"> • Hydraulic connection leaks. • Non-return valve is not adjusted correctly. • No power on the electromagnetic changeover valve <p>Remedy</p> <ul style="list-style-type: none"> • Check all hydraulic connections. |

Maintenance

| | |
|--|---|
| | <ul style="list-style-type: none">• Check the position of the control valve on the implement.• Check the electrical lines, connection of the plug-type connector, and the fuse |
|--|---|

7 Repair

If there are faults, problems, or other indications of malfunction, contact your sales partner.

8 Disposal

The CLS must be disposed of in accordance with the applicable regulations of the municipality or the country.

Take the parts to the collection points for residual waste, special waste, or recycle them depending on material.

matev GmbH does not provide any disposal services.

9 Guarantee

The general terms and conditions of matev GmbH apply.

10 Technical data

| Type designation | Units | CLS-G/H 1050 | CLS- G/H 1350 | CLS- G/H 1650 |
|---|-------|-----------------|---------------------|---------------------|
| Dimensions | | | | |
| Maximum width approx. | mm | 1490 | 1490 | 1490 |
| Total height (with standard tires) approx. | mm | 2030 | 2030 | 2030 |
| Length (from the lower receptacle rear three-point linkage) approx. | mm | 1250 | 1450 | 1650 |
| Max. lift height, high-dump approx. | mm | 2050 | 2050 | 2050 |
| Collection container capacity approx. | L | 1050 | 1350 | 1650 |
| Necessary oil pressure on the tractor approx. | bar | 75 | 95 | 135 |
| Empty weight (without accessories) approx. | kg | 500 | 510 | 520 |
| Total weight (filled without accessories) approx. | kg | 850 | 960 | 1070 |
| Turbine and drive | | | | |
| Turbine speed (standard) approx. | rpm | 2540 | 2540 | 2540 |

List of illustrations

11 List of illustrations

Fig. 1: Arrest bolts10
Fig. 2: Lower link bolt10
Fig. 3: Align the implement10
Fig. 4: Check universal joint shaft12
Fig. 5: Mounting of the suction port and suction hose12
Fig. 6: Suction hose on the turbine13
Fig. 7: Low-dump15
Fig. 8: Lift cylinder safeguard.....15
Fig. 9: Container lifted out, cover closed.....16
Fig. 10: Spring cotter pin – filter mat16
Fig. 11: Retaining rod – filter cloth.....17
Fig. 12: Remove filter cloth17

