

MOW-MM-152 for NH Boomer 25

Operating Manual

Multifunction mower



Table of contents

Table of contents	2
1 Introduction	4
2 About this operating manual	5
3 Technical data	6
3.1 Basic unit MOW-MM-152	6
3.2 Hydraulic lifting	6
3.3 Hydraulic power diagram	7
4 General safety notices	8
4.1 Depiction of safety information	8
4.2 Intended use	8
4.3 Instructions for the owner	9
4.3.1 Qualifications of assembly and maintenance personnel	9
4.3.2 Qualifications of operating personnel	9
4.3.3 Accident prevention	9
4.3.4 Instruction	9
4.4 Warning pictograms	9
4.4.1 General warning pictograms	10
4.4.2 Machine-specific notice	10
4.5 Safety devices	11
4.5.1 Guard on the machine	12
4.5.2 Overview provided of blade covers	14
4.5.3 Decals for Safety Notices and General Decals	15
5 Equipment variants	20
5.1 Optionally required accessories	20
5.2 Optional accessories	21
6 Operating the multifunction mower	22
6.1 Area of application	22
6.2 Function	23
6.2.1 Mower insert, rear ejection	23
6.2.2 Mower insert mulching set	24
6.2.3 Mower insert, side ejection	24
6.2.4 Mower insert side ejection with suction port	25
6.2.5 Mower insert borderless mowing	25
6.3 Mowing instructions	26
6.3.1 Clean the work terrain before mowing	26
6.3.2 Mowing irregular areas	26
6.3.3 Mowing large areas	27
6.3.4 Mowing small areas	27

7	Assembly.....	28
7.1	Attach and detach multifunction mower with hydraulic lift.....	28
7.2	Position mower under tractor.....	29
7.2.1	Attachment by passing over the mower.....	29
7.2.2	Attachment by sliding in sideways under the tractor.....	31
7.3	Couple mower to carrier vehicle (lift).....	32
7.4	Connect PTO shaft with mower to tractor.....	33
7.5	Disassembly of the mower.....	33
7.6	Initial assembly of the hydraulic lift.....	34
8	Adjust cutting height for mowing.....	38
8.1	The desired cutting height can be adjusted above the cutting height adjustment from approx. 29 mm to approx. 107 mm.....	38
9	Securing for trips to the site of operation.....	39
9.1	The hydraulic lift is equipped with a transport position.....	39
10	Maintenance.....	40
10.1	Safety during maintenance.....	40
10.2	Maintenance.....	40
10.2.1	Mower blades.....	41
10.2.2	Mounting the V-belt.....	41
10.3	Lubricating schedule.....	42
10.3.1	Maintenance schedule for MOW-MM-152.....	43
10.3.2	Maintenance schedule for Boomer 25 hydraulic lift.....	44
11	Fault.....	45
12	Repair.....	45
13	Disposal.....	46
14	Guarantee.....	46
15	List of illustrations.....	47
16	List of tables.....	47

1 Introduction

Welcome to the matev family

and thank you for purchasing a product from matev GmbH; we appreciate your trust. You have acquired a quality product, if contrary to expectations you should have problems with the implement, contact your responsible sales partner.

Company stamp – sales partner

Please read this entire manual carefully before operating the machine for the first time. The manual describes the handling of the machine in detail and will help you to work safely and effectively.

We will not acknowledge warranty claims for damage resulting from improper use.

Variants may be described in the manual that do not agree with the scope of delivery of your implement.

Please enter the data of the rating plate on the implement in the manual. This information will be helpful in communication if there is a service case.



matev GmbH
90579 Langenzenn

CE

Modell:

Code Nr.:

Fabr. Nr.:

Baujahr:

Ges.Gew.:

Products from matev are subject to change in the interest of technical progress. All information, illustrations, and technical specifications represent the latest status at the time this manual was published. The manufacturer reserves the right to make changes at any time in the interest of technical progress.

The illustrations in this manual are for explanatory purposes and may differ from the actual design.

Regards

matev GmbH

2 About this operating manual

Read this entire manual carefully before operating this machine for the first time.

Keep this manual where it is easily accessible. This will enable you to refer to important information and handling instructions as needed.

When the machine is delivered the owner receives instruction regarding operation and maintenance of the machine from his sales partner.

The owner must ensure that operating and maintenance personnel have been instructed in full scope in the operation and maintenance of the machine.

Listings with bullet points are marked as follows:

- Text
- Text
- Text. . .

Handling instructions are marked in the sequence in which they should be executed, as follows:

1. Text
2. Text
3. Text. . .

When directions (left, right, front, rear) are specified in the operating manual, they always refer to the carrier vehicle's direction of travel.

The front PTO shaft direction of rotation is always specified in the top view from the front. CW (clockwise), CCW (counter clockwise).

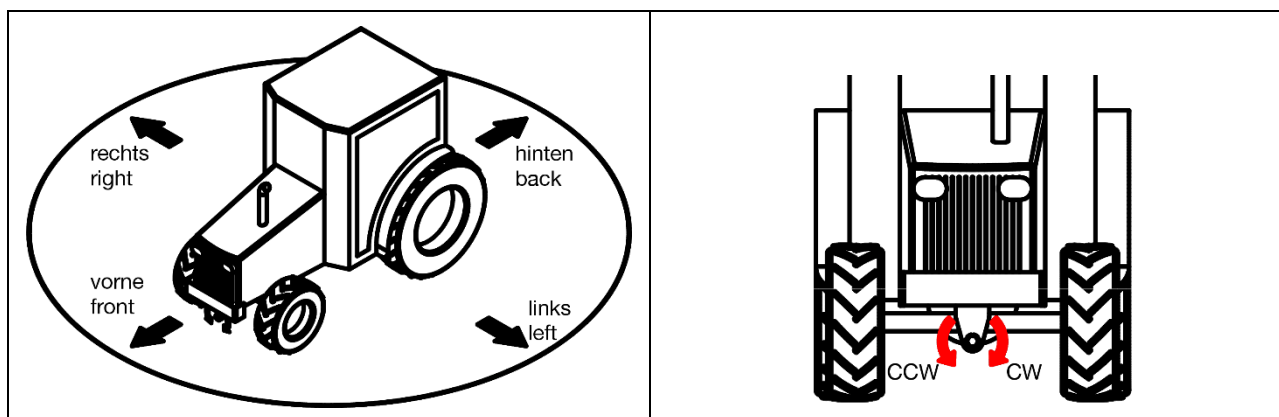

Figure 1 : Definition of orientation and direction of rotation

3 Technical data	
3.1 Basic unit MOW-MM-152	
Mower dimensions L/W/H in mm	816 x 1,580 x 200 with mower insert
Cutting width in mm	1,520 / 60Zoll
Number of blades	3 pcs
Weight	approx. 150 kg (depending on mower use)
Blade rotational speed	approx. 3000 U/min
Suitable for carrier vehicles	20PS-50PS /27KW-67KW
Mid-mount PTO shaft Requirement	CCW 2000 rpm
Transmission oil / lubricating grease	
Transmission capacity	0.5 liters
Transmission oil	Viscosity class 90 e.g. Shell Spira MB90
Transmission oil change	after the first 50 hours then every 500 hours or at season change
Lubricating grease	Multi-purpose grease with a temperature resistance of -30°C to +130°C e.g. lithium universal grease based on mineral oil or similar products.
3.2 Hydraulic lifting	
Cutting height adjustable from to in mm	approx. 29-107 the transport position is at approx. 120 (8 setting options)
Weight	ca. 54kg
Lubricating grease	Multi-purpose grease with a temperature resistance of -30°C to +130°C e.g. lithium universal grease based on mineral oil or similar products.

Table 1 : Technical data

3.3 Hydraulic power diagram

Use the following diagram to determine whether your vehicle provides sufficient hydraulic power.

1. Add up the power specifications of all available options on your machine.
2. Determine the hydraulic specifications of your vehicle.



Notice!

The hydraulic power available to your vehicle is generally much lower than the engine power.

3. Enter the specifications in the table below:

Example: maximum vehicle hydraulic pressure 150 bar. Oil flow rate 40l/min. Result: maximum hydraulic power of approx. 8.8 kW.

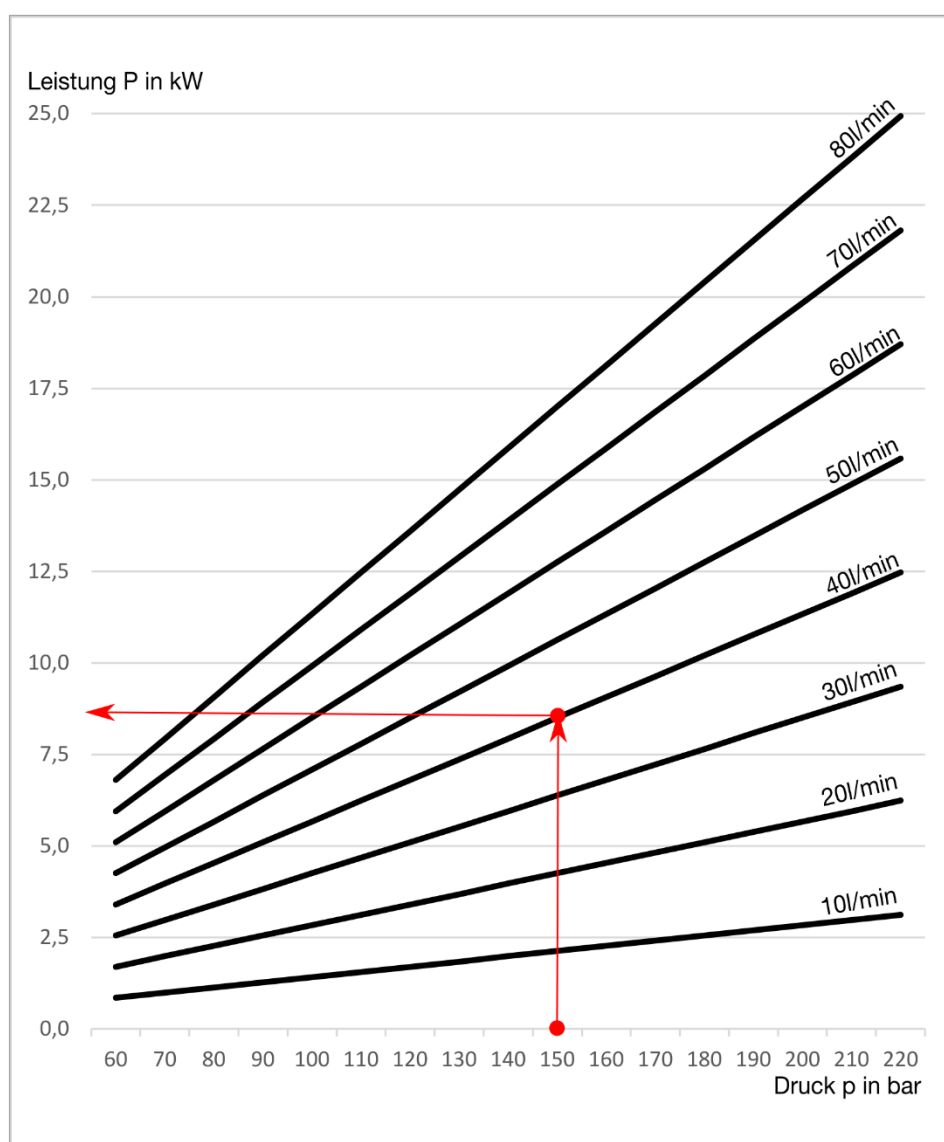

Figure 2 : Hydraulic power diagram

4 General safety notices

This chapter summarizes regulations and information that must be observed in connection with machines.

4.1 Depiction of safety information

The safety information in the text is combined with pictograms and signal words which together indicate the severity of the expected risk



Danger!
Hazardous situations that will result in serious injuries or death.



Attention!
Hazardous situations that could result in moderate injuries or material damage.



Notice!
Recommendations or information for the operator.
Read this notice. It will facilitate your work.

4.2 Intended use



Danger!
To prevent incorrect use, read also through chapter 6.1 Area of application

- The implements are designed for municipal tractors or carrier vehicles used for comparable work.
- They may be operated only on carrier vehicles with the power range specified in the technical data.
- Intended use also includes compliance with the operating, service, and maintenance conditions prescribed by the manufacturer.
- Intended use also comprises the exclusive use of original replacement parts and additional equipment or such components and equipment that meet the manufacturer's technical requirements.
- Unauthorized modifications to the implements will void any liability on the part of the manufacturer.

All other uses are prohibited!

Non-intended use causes:

- Danger of injury to the operator or third parties
- Damage to the carrier vehicle and the implements
- Environmental damage
- Damage to the machine

4.3 Instructions for the owner

4.3.1 Qualifications of assembly and maintenance personnel

Assembly and maintenance of safety-related components may be carried out only by personnel with the following qualifications:

- They must have completed specialized training as an agricultural machinery mechanic, motor vehicle mechanic, etc.
- Personnel without qualified training must be supervised by someone with qualified training.
- They must have read and understood this operating manual.
- They must be familiar with the relevant safety regulations (accident prevention).

4.3.2 Qualifications of operating personnel

- They must be fully instructed on how to operate the machine.
- They must have read and understood this operating manual.
- They must be familiar with the relevant safety regulations (accident prevention).

4.3.3 Accident prevention

The safety regulations and accident prevention regulations are legally regulated in every country. The shop foreman or the assigned occupational safety and health specialist of the company carrying out the work is responsible for compliance with the applicable regulations.

4.3.4 Instruction

When the implement is delivered the owner receives instruction regarding operation and maintenance.

The owner must take measures to ensure that operating and maintenance personnel are fully instructed regarding operation and maintenance.

4.4 Warning pictograms

Warning pictograms point out dangers that cannot be counteracted by means of safety measures. Strict observance of the pictograms is necessary to prevent severe injuries or death.



Danger!

Missing warning notices must be replaced immediately.

Do not operate the machine if warning notices are missing.

You can order warning pictograms with the spare parts numbers specified in chapter 0.

4.4.1 General warning pictograms

This section explains general warning pictograms that are not specific to a particular machine.



Read the operating manual and observe the safety information.



Shut down the engine before performing maintenance and repairs
Remove the key.



Injuries from emerging high-pressure fluid.
Comply with the notice in the operating manual.

4.4.2 Machine-specific notice

This section explains machine-specific warning pictograms and notices for operation and maintenance of the machine.



Do not operate the mower without the discharge guard or suction port!



Only touch machine parts after they have come to a complete standstill!



During operation, maintain a sufficient distance to the mowing blade!



Danger due to thrown-out parts when the engine is running - maintain a safety distance!



Do not position yourself in the area of the drive shaft!

max. Drehzahl
2000 U/min.

Implement is suitable for a PTO shaft speed of 2000 rpm only!
Mainly mid-mount, front-end or independent engine PTO shafts.



Tighten all screws after each use



Lubricating point

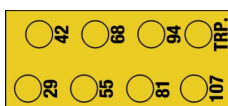

Cutting height adjustment MOW-MM-150 Boomer 25

4.5 Safety devices

Machines are equipped with various safety devices to protect people who work with a machine or are in the direct vicinity of the machine while working, to avoid premature wear and also to prevent environmental damage. These safety devices are integral components of the machine; it is prohibited to manipulate or remove them. Missing or damaged safety devices must be replaced immediately.

There are two types of safety devices: those that prevent contact with the hazard point, and those that point out a hazard on the machine.

Hazards can also arise as a result of insufficient maintenance, so that warning notices are also to be regarded as a type of safety notice.



Before each use of the machine, ensure that all of the safety devices described here are complete and fully functional. Do not operate the implement if any safety devices are missing or damaged.

4.5.1 Guard on the machine

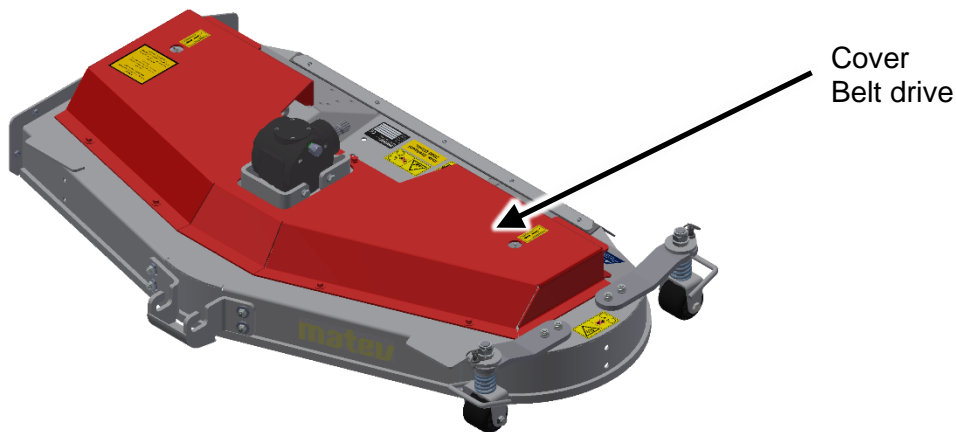

Figure 3 : Belt drive cover

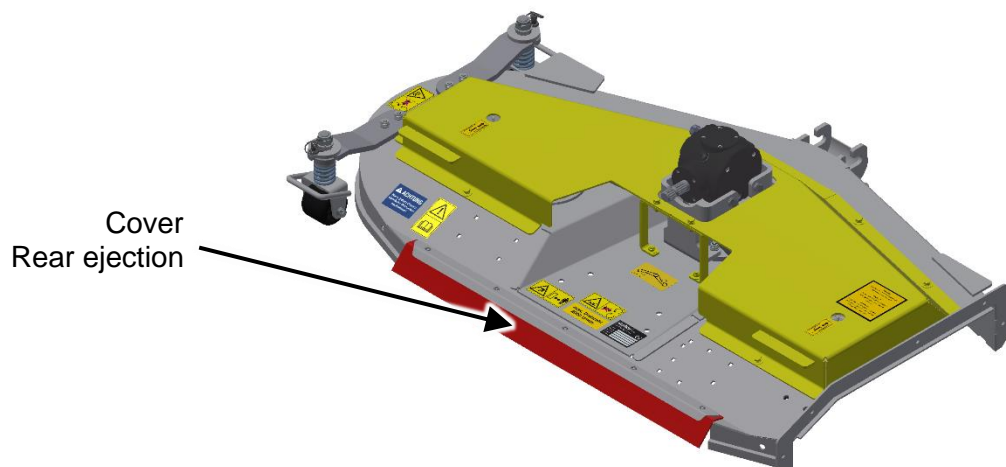

Figure 4 : Rear ejection cover

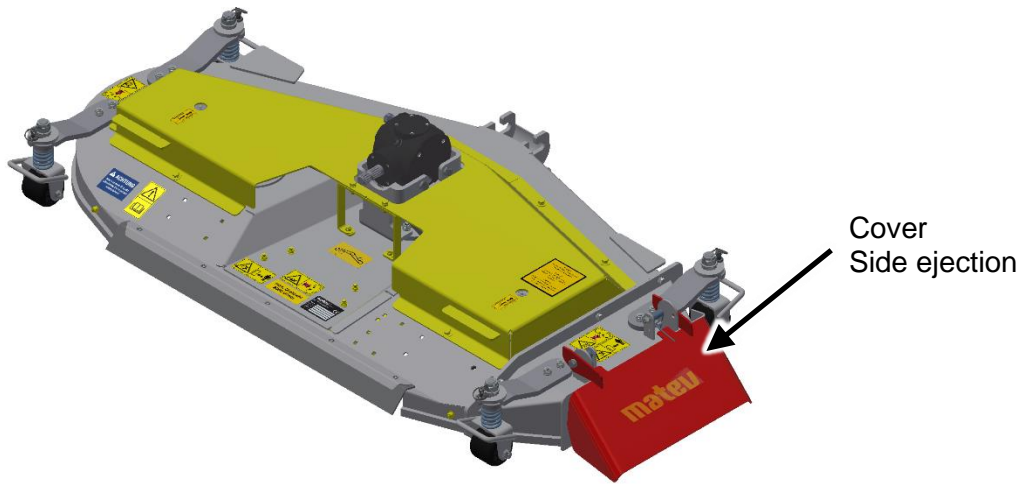

Figure 5 : Side ejection cover



Do not operate the mower without the mower insert and cover!
The blades must always be covered with an insert and cover provided for this purpose.

4.5.2 Overview provided of blade covers

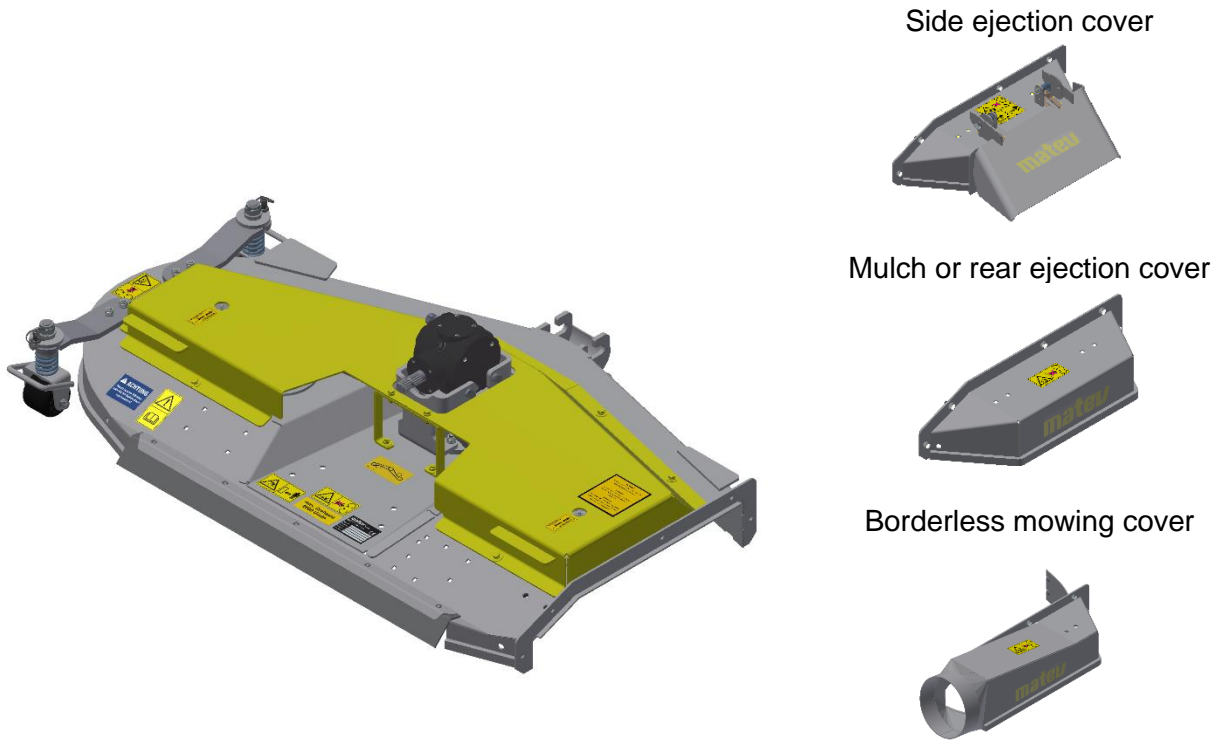

Figure 6 : Blade cover overview

4.5.3 Decals for Safety Notices and General Decals

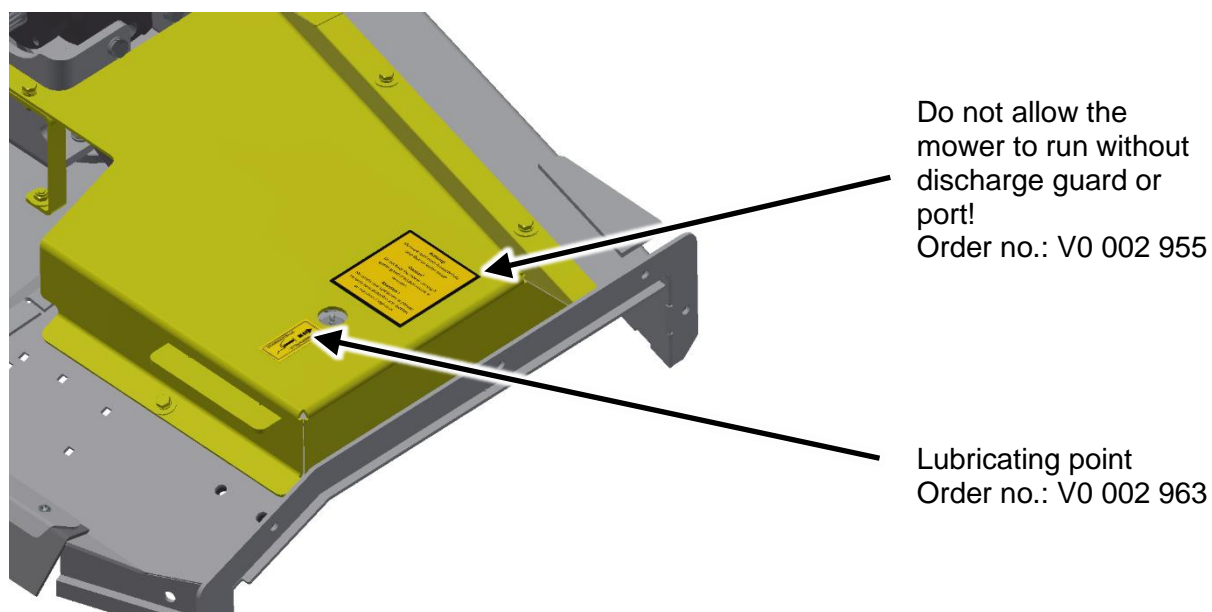

Figure 7 : Safety notice Protection

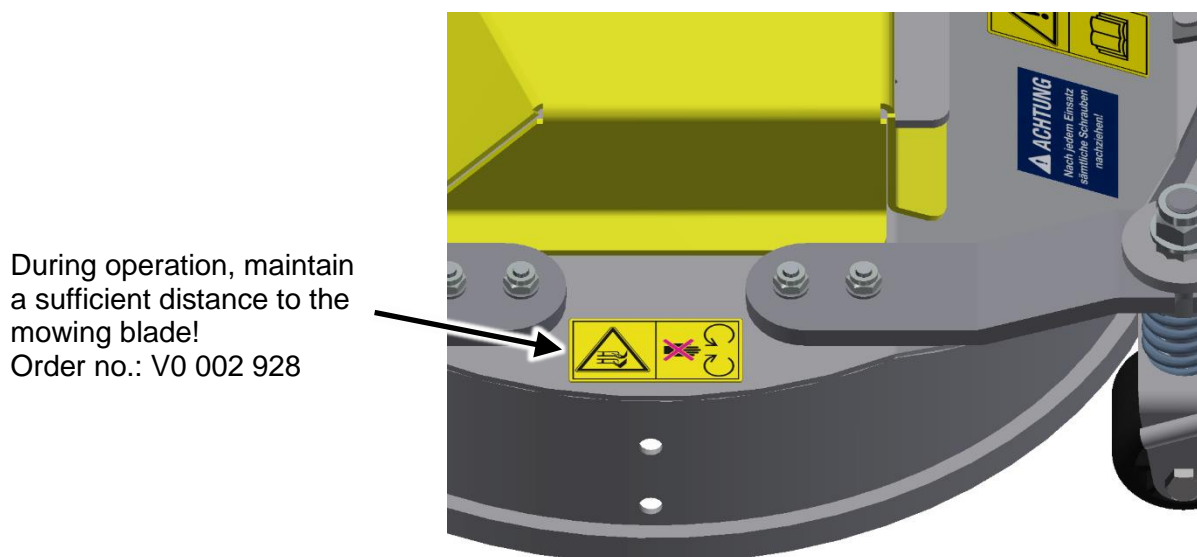

Figure 8 : Safety notice Mower blade

Tighten all screws after each use!
Order no.: V0 002 965

Read the operating manual and observe the safety information
Order no.: V0 002 922

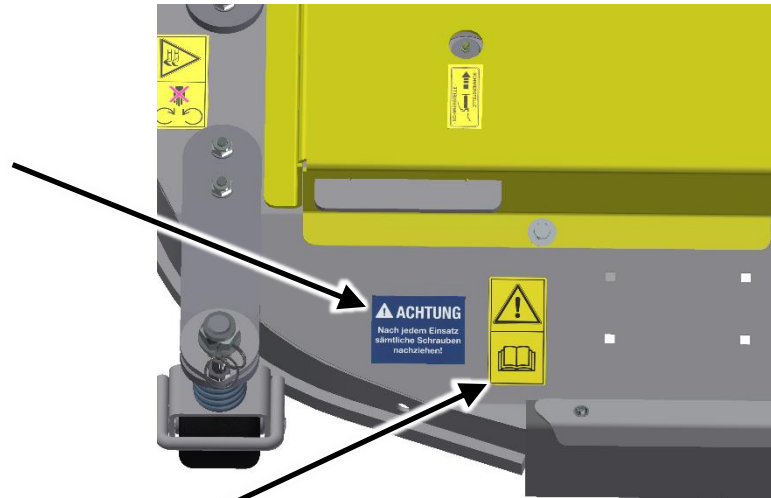
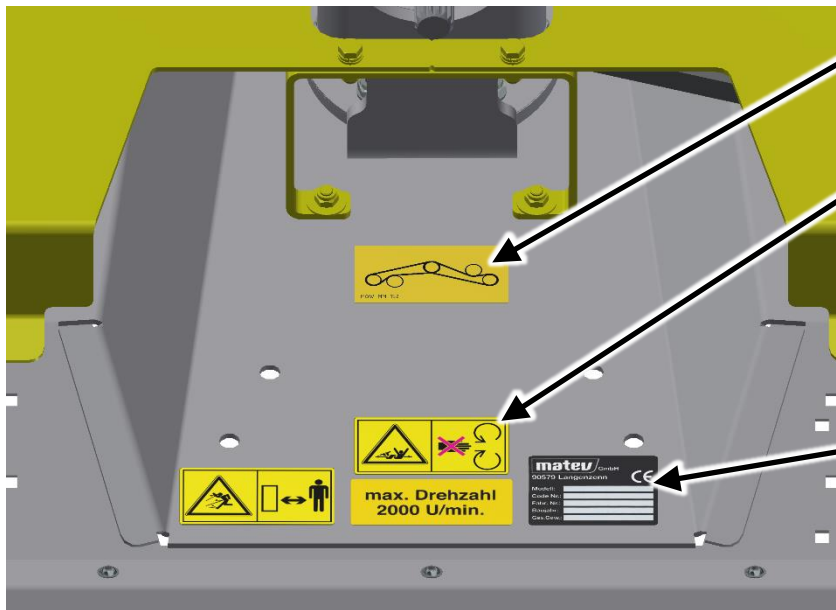

Figure 9 : Safety notice Read operating manual and retighten screws



Belt guide
Order no.: V0 003 519

Do not position yourself in the area of the drive shaft.
Order no.: V0 002 930

Type plate

Figure 10 : Safety notice Drive shaft and belt guide, type plate

Danger due to parts being thrown
Order no.: V0 002 931

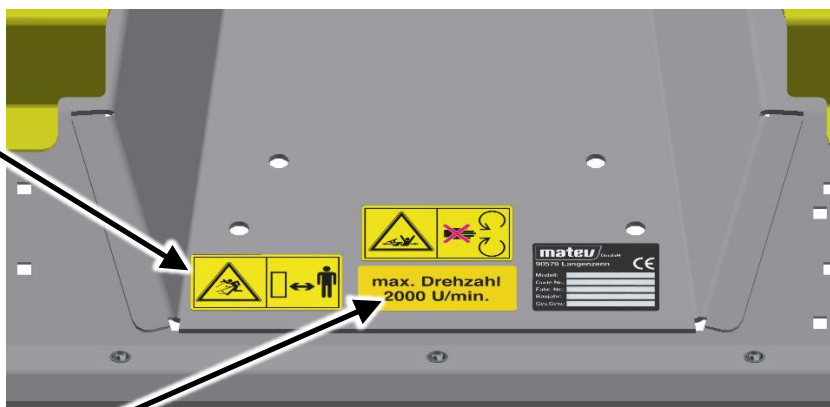

max. rotational speed
2000
Order no.: V0 002 947

Figure 11 : Position of type plate and speed specification

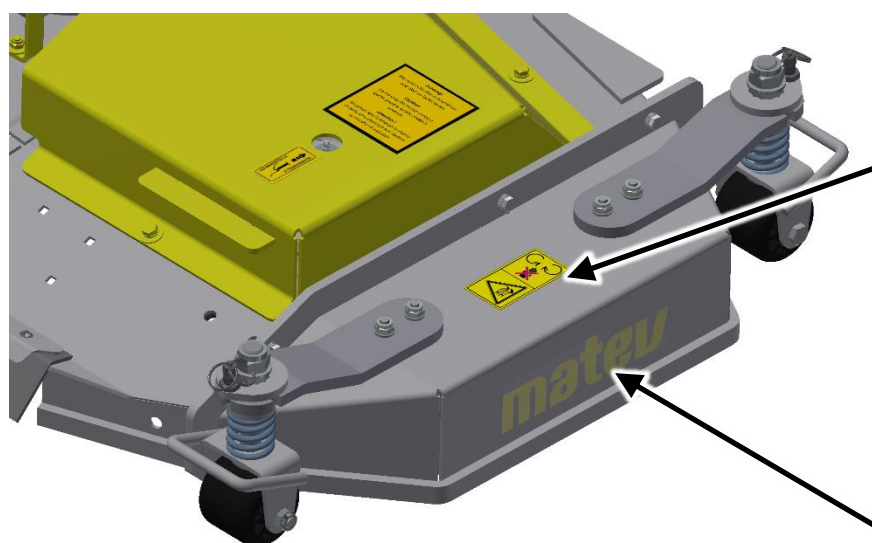

During operation, maintain
a sufficient distance to the
mowing blade!
Order no.: V0 002 928

matev logo
Order no.: V0 003 094

Figure 12 : Safety notice Mower blade on cover Mulching or rear ejection

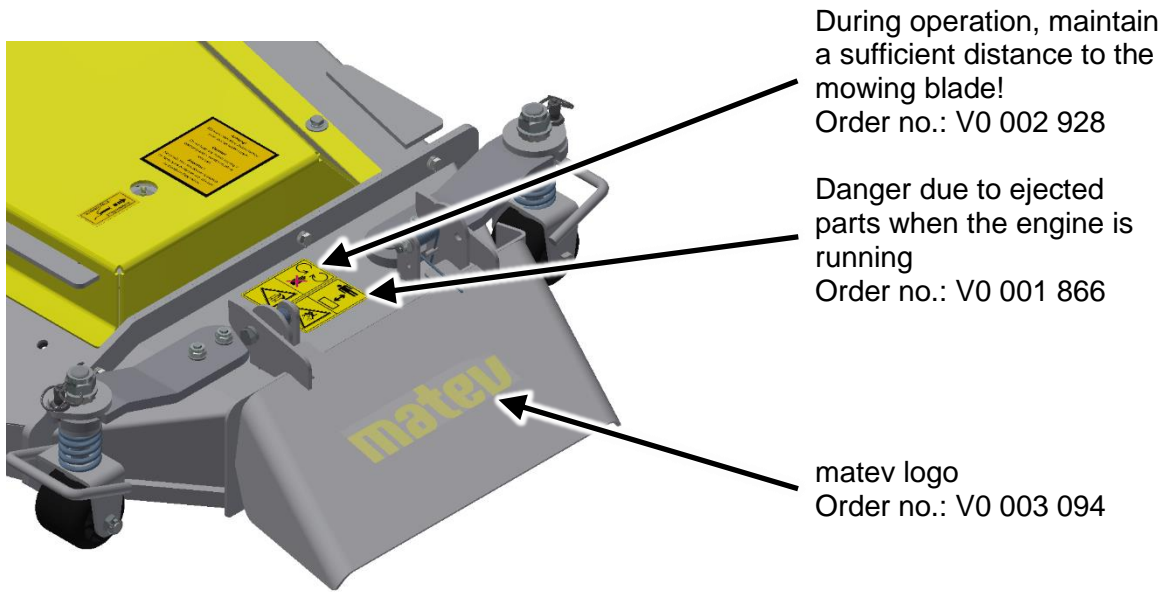

Figure 13 : Safety notice Mowing blades and propelling parts on cover Side ejection

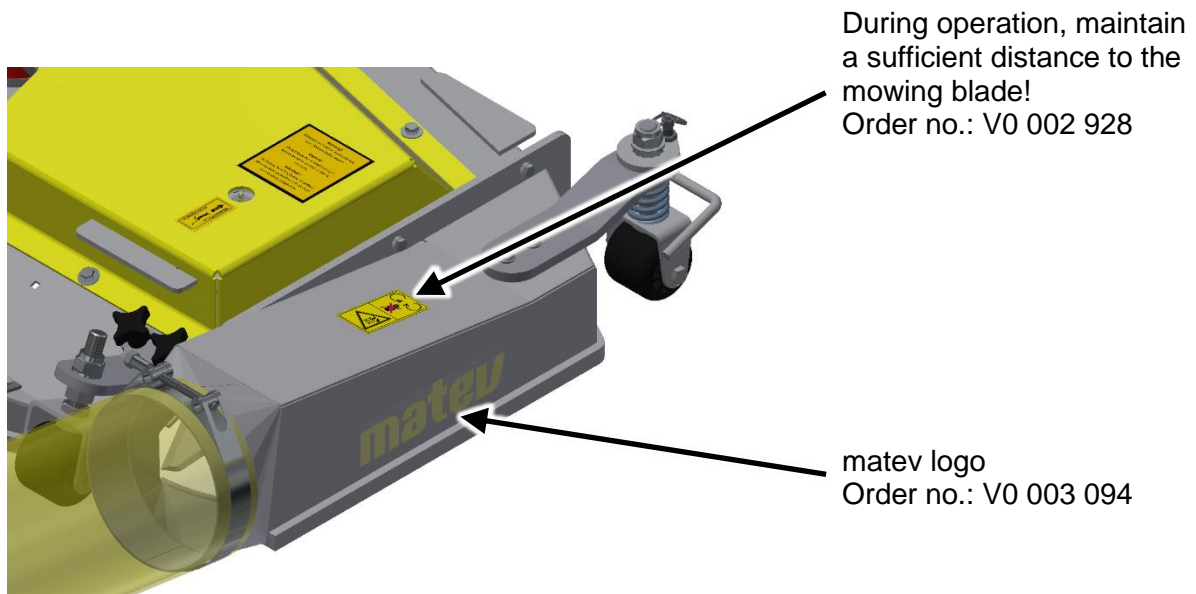

Figure 14 : Safety notice Mower blade on cover Borderless mowing

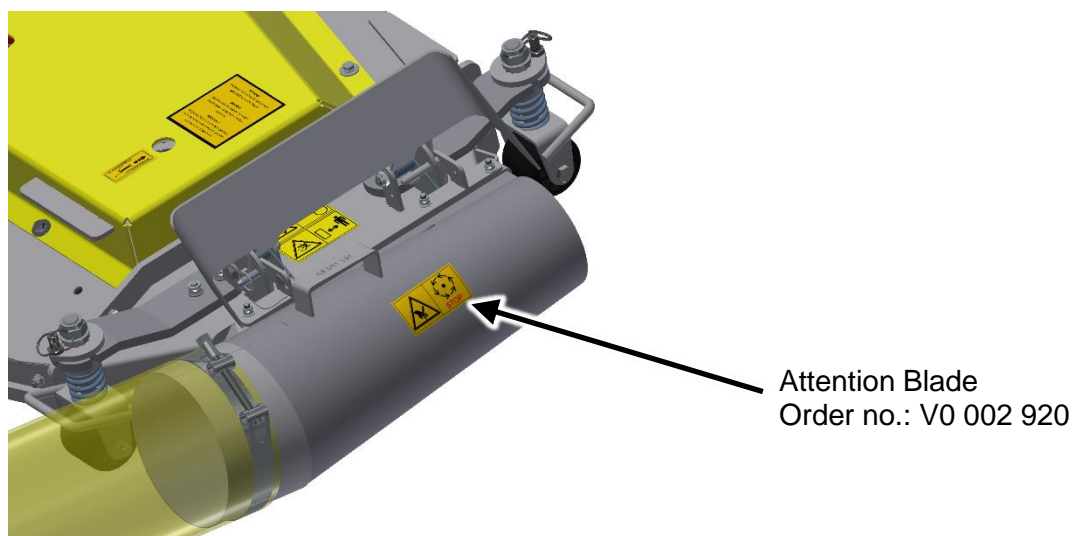

Figure 15 : Safety notice Mower blade on suction port

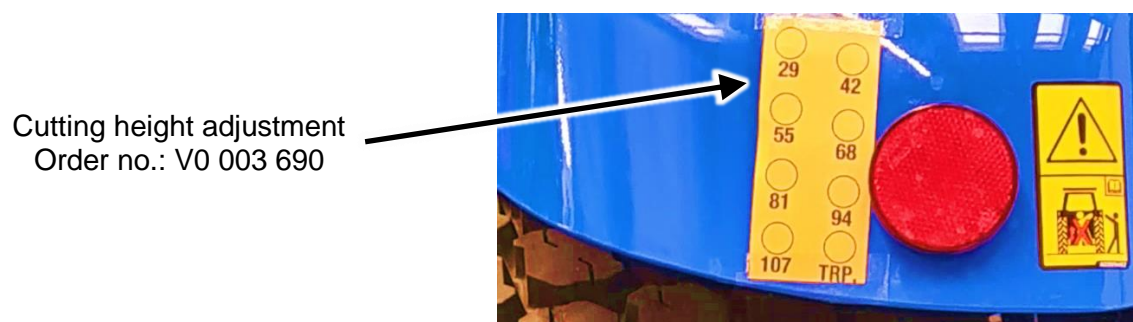





Figure 16 : Cutting height adjustment

5 Equipment variants

5.1 Optionally required accessories

	<p>Mower insert, rear ejection</p>
	<p>Mower insert mulching</p>
	<p>Mower insert, side ejection</p>
	<p>Mower insert borderless mowing</p>

5.2 Optional accessories

	<p>Connection with suction hose</p> <p>Attention! The suction port is only available in conjunction with the side ejection mower insert.</p>
	<p>MOW-MM-152 Quick change system</p>

6 Operating the multifunction mower



When working on the mower and parking the mower, make sure that it is placed on a level, solid surface and secured against rolling away by turning the wheels.



Secure the machine against inadvertent startup by disconnecting it from the vehicle, or by switching off the vehicle, removing the ignition key.



Before starting the mower, read the safety and handling instructions for operating the entire unit and lifting it to the carrier vehicle.



When mowing, adjust the travel speed to the grass to be mowed or the cutting height and amount of cut. A recommended working speed is between 3 and 8 km/h.



The cutting pattern depends on many factors:
Grass characteristics: Grass height, grass density, grass species, and moisture of the grass, driving speed and the cutting height.



Never reach into the mower when the blades are rotating. Switch off the tractor and remove the ignition key before you reach into the mower. Attention: The mower blades continue to rotate after the engine is switched off. Make sure the blades have come to a complete stop before reaching into the mower.



Always make sure that there are no persons in the working area before mowing.



When driving on the road, the mower must be completely lifted and secured with the pin in the TRP position.

6.1 Area of application

The mower is used for mowing green areas, agricultural land. The area of application extends from manicured lawns, to matted grass to uncultivated land. The working speed with the multifunction mower should not exceed walking speed.

6.2 Function

The multifunction mower works with three rotating blades which are driven by the tractor via the mid-mount PTO shaft.



The instructions for installing the various mower inserts can be found in the installation manual [*mow-mm-152-mid-mount-mower-operating-manual-37551-matev*](#)

6.2.1 Mower insert, rear ejection

Grass is transported to the rear, is ejected and remains on the ground.

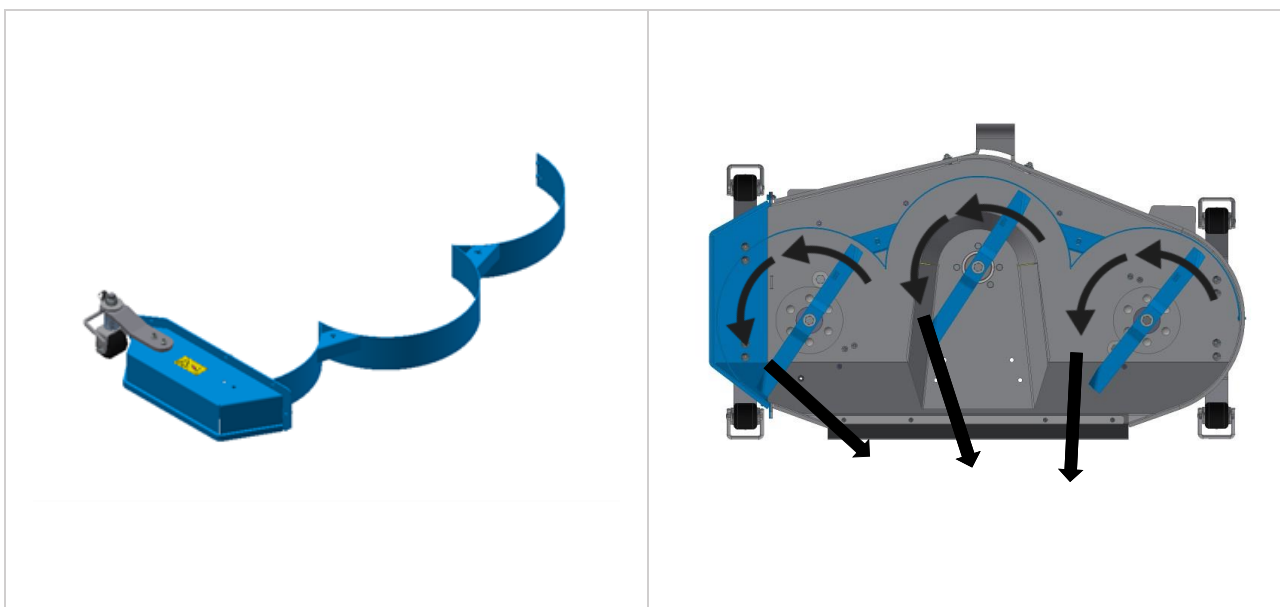

Figure 17 : Rear ejection grass flow

6.2.2 Mower insert mulching set

Grass remains in the suction of the blades and is therefore cut more often and remains on the ground.

Thus serves as a biological fertilizer.

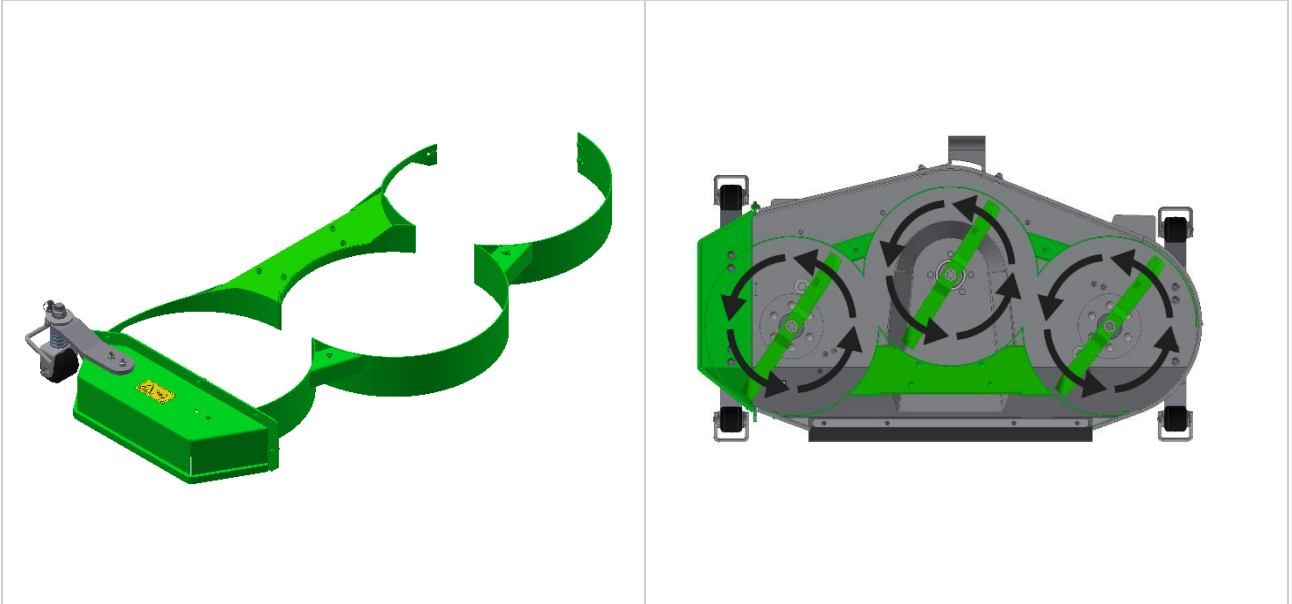

Figure 18 : Mulch insert grass flow

6.2.3 Mower insert, side ejection

Grass is transported to the side and ejected.

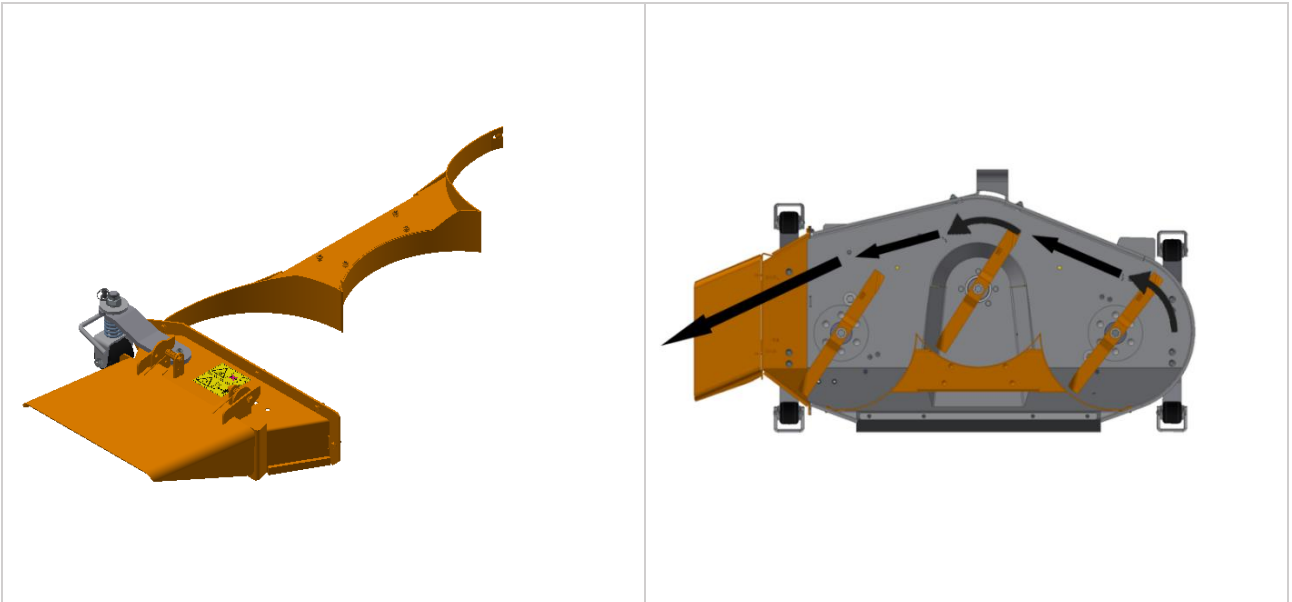

Figure 19 : Side ejection grass flow

6.2.4 Mower insert side ejection with suction port

Grass is transported to the side and suctioned off e.g. by a CLS from matev.

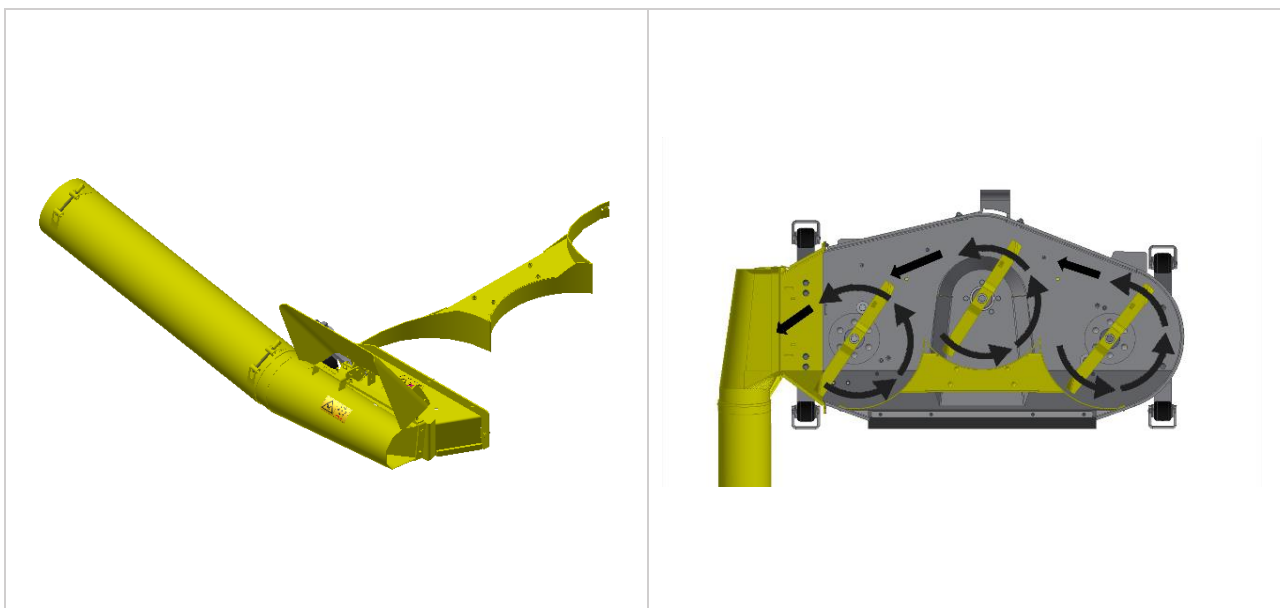

Figure 20 : Side ejection with suction port grass flow

6.2.5 Mower insert borderless mowing

Grass is transported to the side and suctioned off e.g. by a CLS from matev.

The advantage of this port compared to the normal port Figure 19 is that you can mow up to the edge of the lawn or curbs, house walls and borders, which means that mowing is almost borderless.

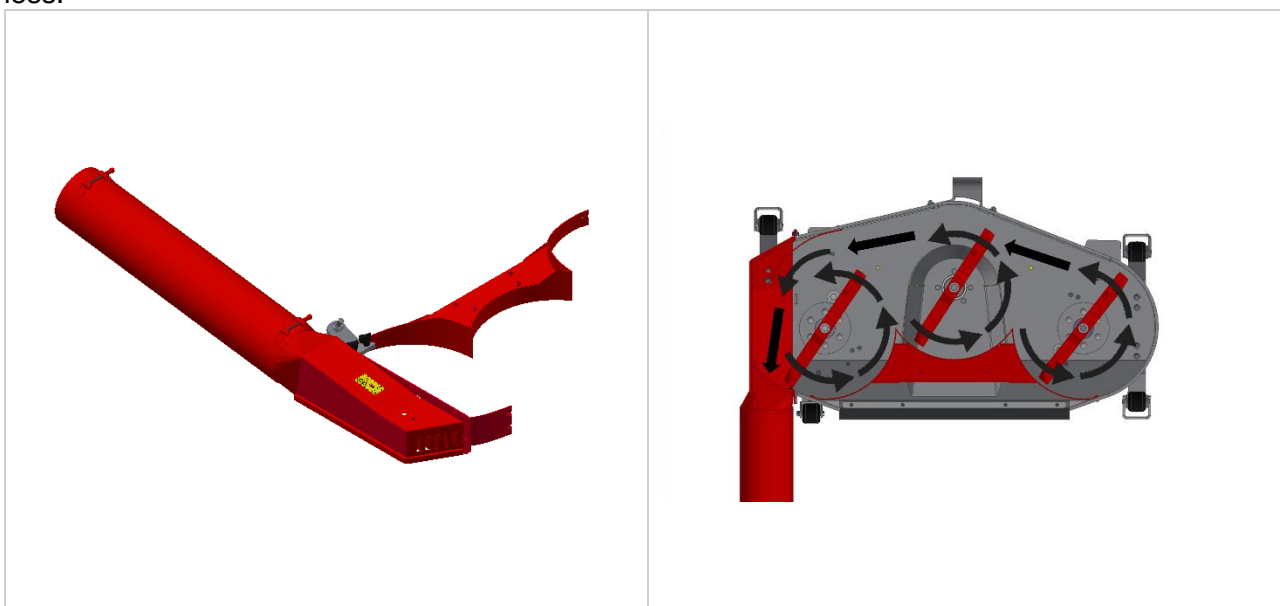

Figure 21 : Borderless mowing grass flow

6.3 Mowing instructions

6.3.1 Clean the work terrain before mowing



Figure 22 : Clean the work terrain



Ensure that the working area is free of objects that could cause damage to the mower or blades, or could be ejected from the mower.

6.3.2 Mowing irregular areas

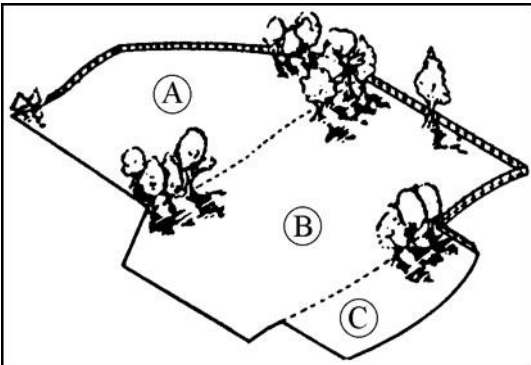

Figure 23 : Irregular area

Divide irregular areas into smaller sections.

Change the mowing pattern frequently; do not always work in the same pattern.

6.3.3 Mowing large areas

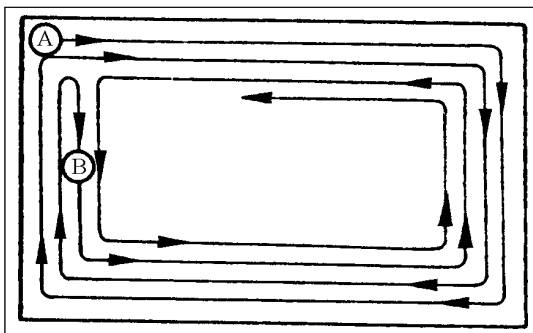

Figure 24 : Mowing large areas

Mow large, open areas as shown in the figure.

6.3.4 Mowing small areas

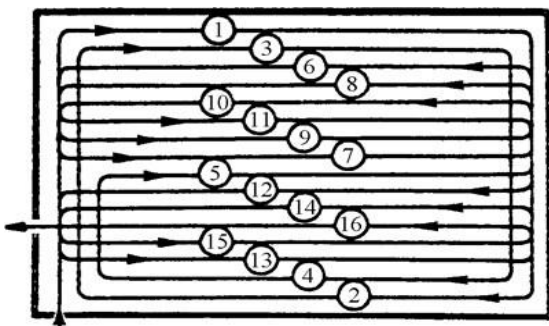

Figure 25 : Mowing small areas

If you do not use a collection container, mow small areas as shown in the figure.

Two to three rounds clockwise, the rest counterclockwise. Thus you prevent the mower from repeated clogging due to accumulated cuttings.

7 Assembly

7.1 Attach and detach multifunction mower with hydraulic lift.



Before mounting the multifunction mower, be sure to read chapter 7.6Initial assembly of the hydraulic lift.

The multifunction mower is delivered fully assembled by your dealer. If you subsequently purchase accessories, such as a mower insert, these accessories will also be fully assembled by your dealer.

Your dealer will instruct you in the handling and all safety aspects of the multifunction mower as well as the lift and accessories provided for it.



Danger!

The multifunction mower and the hydraulic lift must not be operated without safety instruction. The operator is responsible for ensuring that all operators of the multifunction mower and the hydraulic lift are trained.



The multifunction mower and hydraulic lift is specially configured for your tractor with matev front power system and without front power system. It cannot be operated on another tractor model or with another front power system.

7.2 Position mower under tractor

The mower can be positioned under the tractor by driving over it (-> Chapter 7.2.1) or pushing it in sideways (-> Chapter 7.2.2)

7.2.1 Attachment by passing over the mower.



The matev front power system must be dismantled in order to drive over the mower!

1. Center the mower in front of the tractor.



Figure 26 : Positioning the mower

2. Slowly drive over the mower with the tractor (switch on all-wheel).



Lifting (lifting arm) must be raised.



Figure 27 : Drive over mower

7.2.2 Attachment by sliding in sideways under the tractor.

1. Pull the locking bolt and turn the wheel 90°, the bolt engages automatically. Repeat for all wheels.

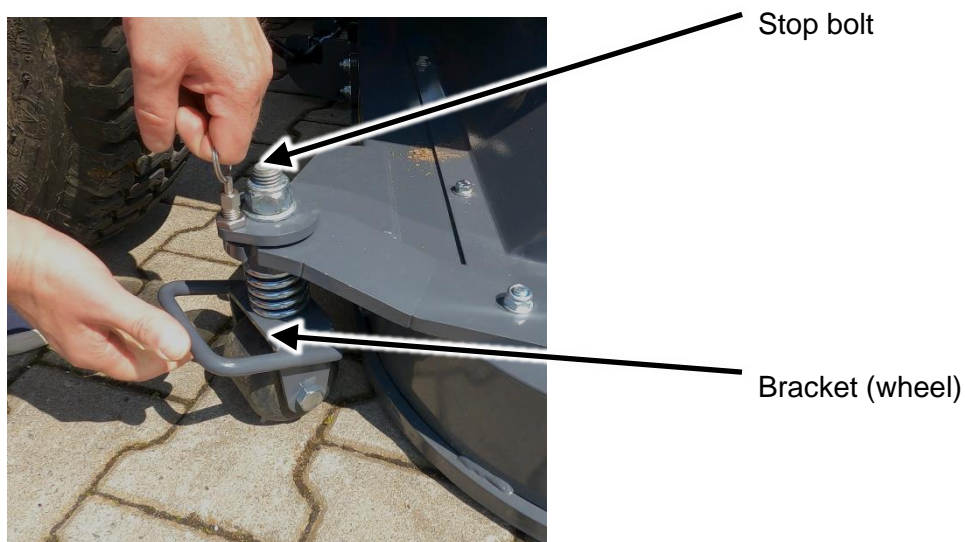

Figure 28 : Rotate wheel 90°



Lifting (lifting arm) must be raised.

2. Push the mower under the tractor from the side using the matev quick-change system. The matev quick-change system is optionally available. Refer to page 21.



Figure 29 : Push the mower sideways under the tractor

7.3 Couple mower to carrier vehicle (lift)



Switch off the carrier vehicle and remove the ignition key before mounting or dismounting the mower.

1. Hook the front bracket onto the mower, connect it to the pin on the tractor (lugs) then secure the pins with the linchpin.

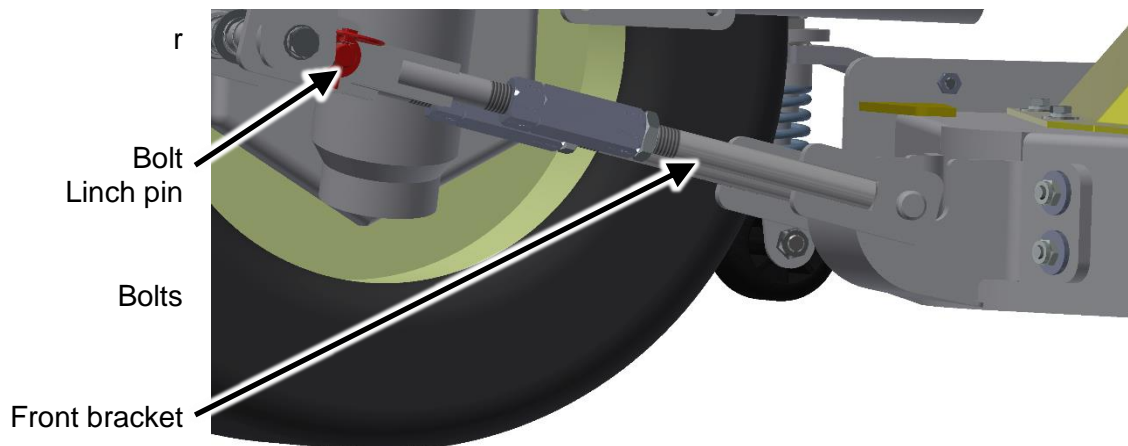

Figure 30 : Hanging the front bracket on the mower

2. Operate the hydraulics so that the lift (lifting arm) drops down.
Connect the left and right lifting arms to the mower with the pin, then secure the pin with the linch pins.

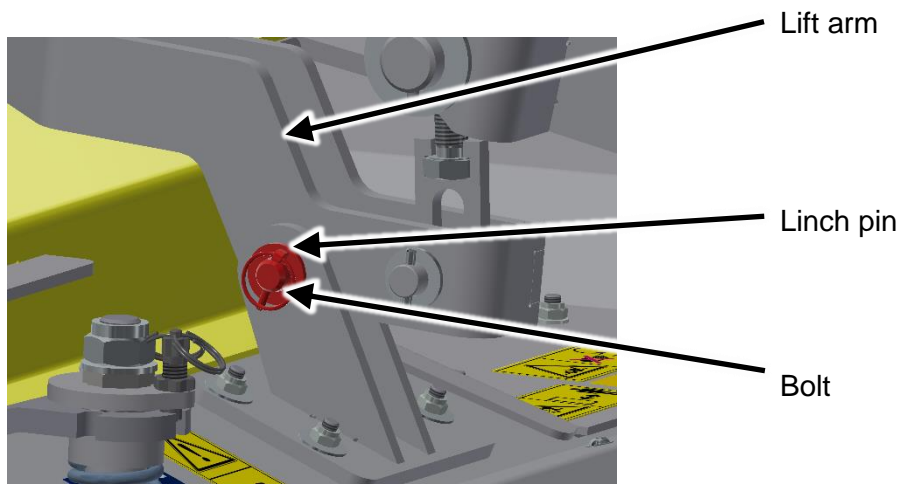

Figure 31 : Connect lift arm to mower

7.4 Connect PTO shaft with mower to tractor



Only use the provided universal joint shaft. Comply with the instructions in the operating manual (assembly instructions) provided by the manufacturer of the universal joint shaft. The PTO shaft must be adjusted according to the carrier vehicle.



Depending on the carrier vehicle, the PTO shaft supplied may be too long. Follow the steps described in the original PTO shaft manufacturer's instructions to shorten and install the PTO shaft. If you lose the manual, please contact matev GmbH.



The PTO shaft guard must be removed before installation in the tractor.



The mower must be matched to the speed of the PTO shaft of the carrier vehicle.

7.5 Disassembly of the mower

To disassemble the mower, the steps listed up to this point must be applied backwards.

7.6 Initial assembly of the hydraulic lift



During the initial assembly of the hydraulic lift, a one-time adjustment is necessary.

1. Adjust the mower to the front bracket

- The mower must stand on the ground
- Use the two tension sleeves (nuts) on the front bracket to tighten the mower.

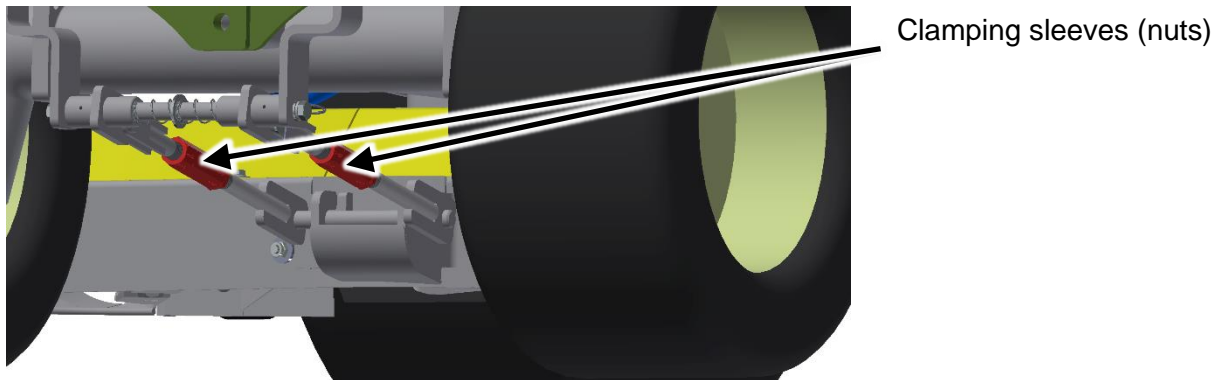

Figure 32 : Adjusting the mower on the front bracket

2. Adjust the mower on the rear suspension.

- Turn the nut on the suspension until the suspension is under tension.
Repeat the same on the other side, making sure that the mower is set horizontally.

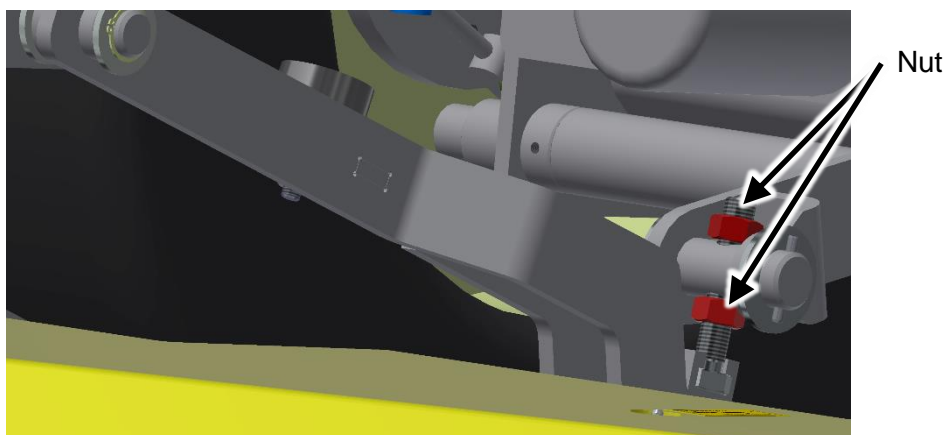

Figure 33 : Adjust the mower on the rear suspension

3. Fine adjustments to the cutting height adjustment and rear suspension

- Completely lift the mower with the hydraulic lift.
- Mark e.g. 81 on the cutting height adjustment.

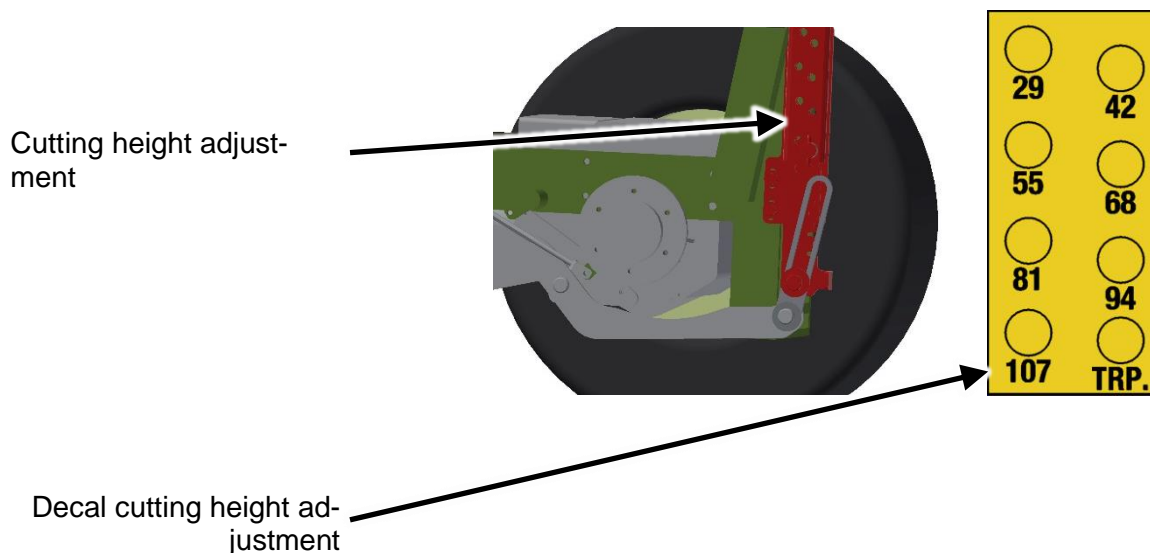

Figure 34 : Cutting height adjustment

- Lower the mower with the hydraulic lift until the mower is stopped by the cutting height adjustment.
- Measure the blades with a suitable measuring tool



As a reference for alignment (adjustment), always measure on the blades with a suitable measuring tool.

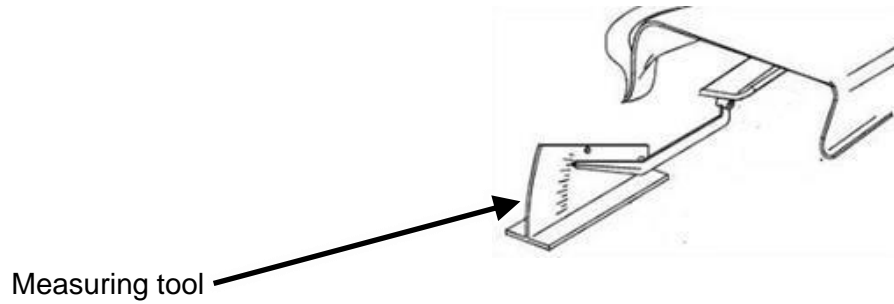

Figure 35 : Measuring tool

- Adjust the mower with the rear suspension so that the specified cutting height is obtained on the blades (measuring tool).

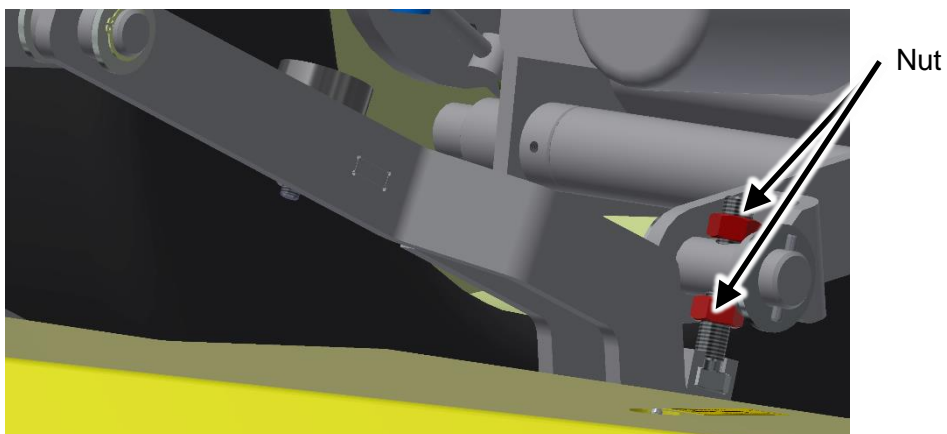

Figure 36 : Adjust rear suspension

- If necessary, fine tuning can be made above the cutting height adjustment. To do this, proceed as follows: Loosen screws and move up or down. Retighten the screws.

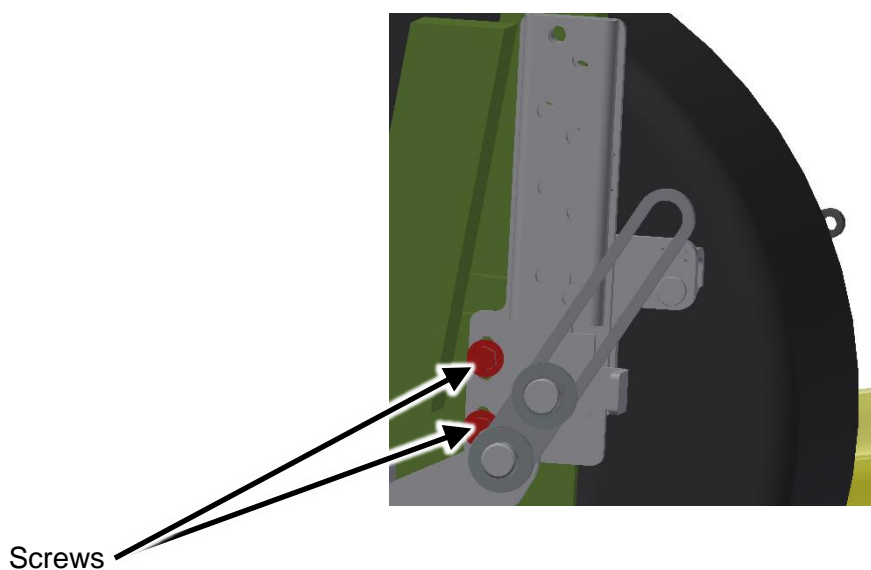

Figure 37 : Adjustment screw for cutting height adjustment

- Adjusting the inclination: using the clamping sleeves of the front bracket. Refer to Figure 32

The mower tilts by turning the clamping sleeves. The inclination of the mower must be approx. 0.5° towards the front, which corresponds to approx. 6 mm difference from front to back.

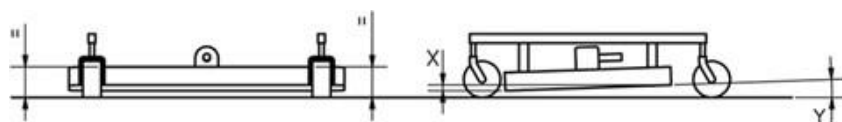

Figure 38 : Adjust inclination



Once the mower is adjusted to the cutting height and inclination, tighten all nuts.

8 Adjust cutting height for mowing

8.1 The desired cutting height can be adjusted above the cutting height adjustment from approx. 29 mm to approx. 107 mm.



The actual cutting height depends on many factors, such as tire pressure, using different tires than when first delivered, etc.

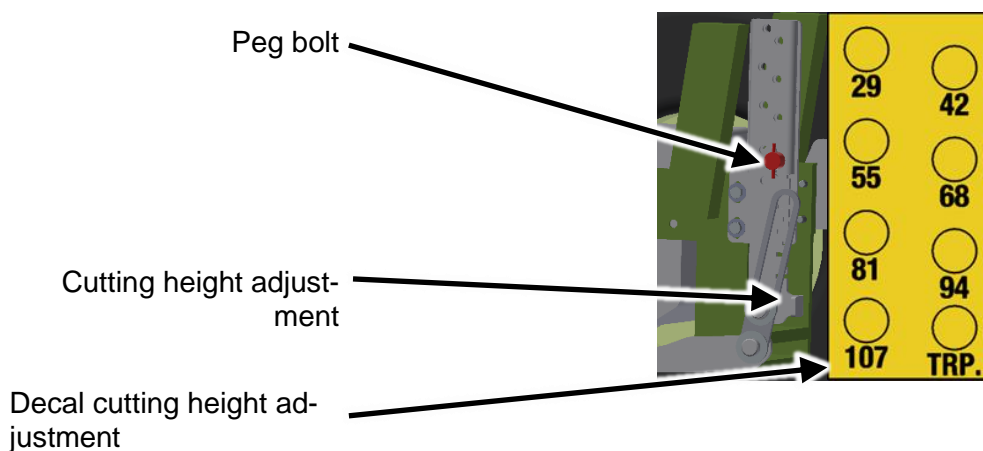

Figure 39 : Adjusting the cutting height

1. Completely lift the mower with the hydraulic lift.
2. Pull the locking pin
3. Set the desired cutting height and insert and secure the locking pin at the desired cutting height
4. Lower the mower with the hydraulic lift until the mower is stopped by the cutting height adjustment.
5. Mowing can begin.

9 Securing for trips to the site of operation



When driving on the road, the mower must be completely lifted and secured with the pin in the TRP position.

9.1 The hydraulic lift is equipped with a transport position.

1. Completely lift the mower with the hydraulic lift.
2. Position the cutting height adjustment in the TRP position so that the holes are aligned.
3. Insert the pin into the marked TRP hole and secure it.

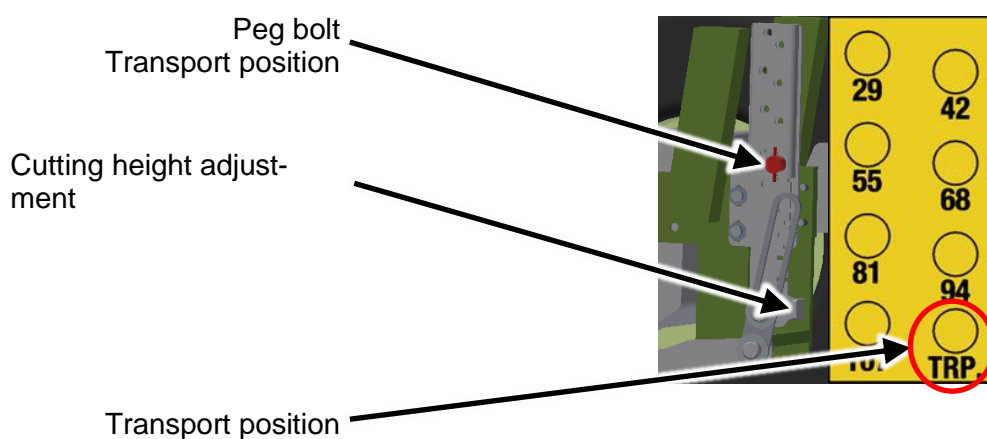

Figure 40 : Securing during trips to the site of operation

10 Maintenance

10.1 Safety during maintenance



Personal injury and material damage to the tractor and implements can occur. Before each use of the implements check all safety-relevant parts and the hydraulic connections.



The attachment must not be switched on during maintenance work. Switch off the carrier vehicle engine and remove the ignition key.



Danger of crushing due to moving parts. Never reach into the crushing hazard zone if parts are moving or can move.



Properly reattach all protective devices that have been dismantled after executing the maintenance tasks.



After the first 20 hours of operation check all screw and bolt connections. Subject the implement to regular maintenance. Use lubricating grease to lubricate the moving parts. See lubrication schedule.

10.2 Maintenance

To ensure serviceability and compliance with occupational safety requirements, the following tasks must be carried out after each use.

- Cleaning the machine.
- Check to ensure that all safety notices and safety devices are complete and functioning.
- Inspect hydraulic connections and hoses for leaks. Be sure to also check the age of the hoses.
- It is recommended to replace hydraulic hoses every 6 years.
- Inspect wear parts such as V-belts, blades, etc. and replace, if necessary, or have them replaced.
- Check all screw and bolt connections. Tighten any loose screws and secure loose bolt connections with the securing elements provided.

10.2.1 Mower blades

The blades are wear parts and must be sharpened and balanced regularly. If necessary, they can also be exchanged.



Wear suitable protective equipment for the installation and removal of the mower blades.



Should the mower blade be damaged by an object, e.g. a stone, it must be replaced immediately. Do not operate the mower with the damaged blade.

10.2.2 Mounting the V-belt

If you have to change the V-belt, make sure that the belt is correctly routed during assembly, as shown in the figure

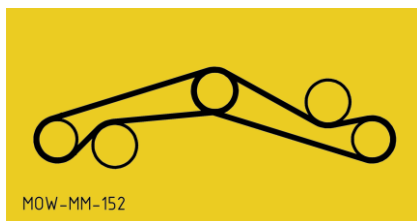

Figure 41 : Belt guide



The springs of the tension pulley are tensioned. Ensure that both ends of the springs are hooked in correctly. After changing the belt, the belt tensioner must be readjusted (tensioned).



Do not operate the mower with missing or damaged belt covers.

10.3 Lubricating schedule

Moving parts of the implement must be greased at regular intervals, as well as at the start and end of the season.



Symbol	Meaning
1/d	Lubricate daily
1/30h	Lubricate every 30 operating hours
2/a (1/500h)	Lubricate at the beginning and end of the season and after 500 operating hours
	Use a grease gun
	Check oil level, top-up oil if necessary Change oil after every x hours of operation
	Please comply with the operating manual provided for this component. The lubricating intervals are specified in the operating manual

Table 2 : Lubrication schedule symbols

10.3.1 Maintenance schedule for MOW-MM-152

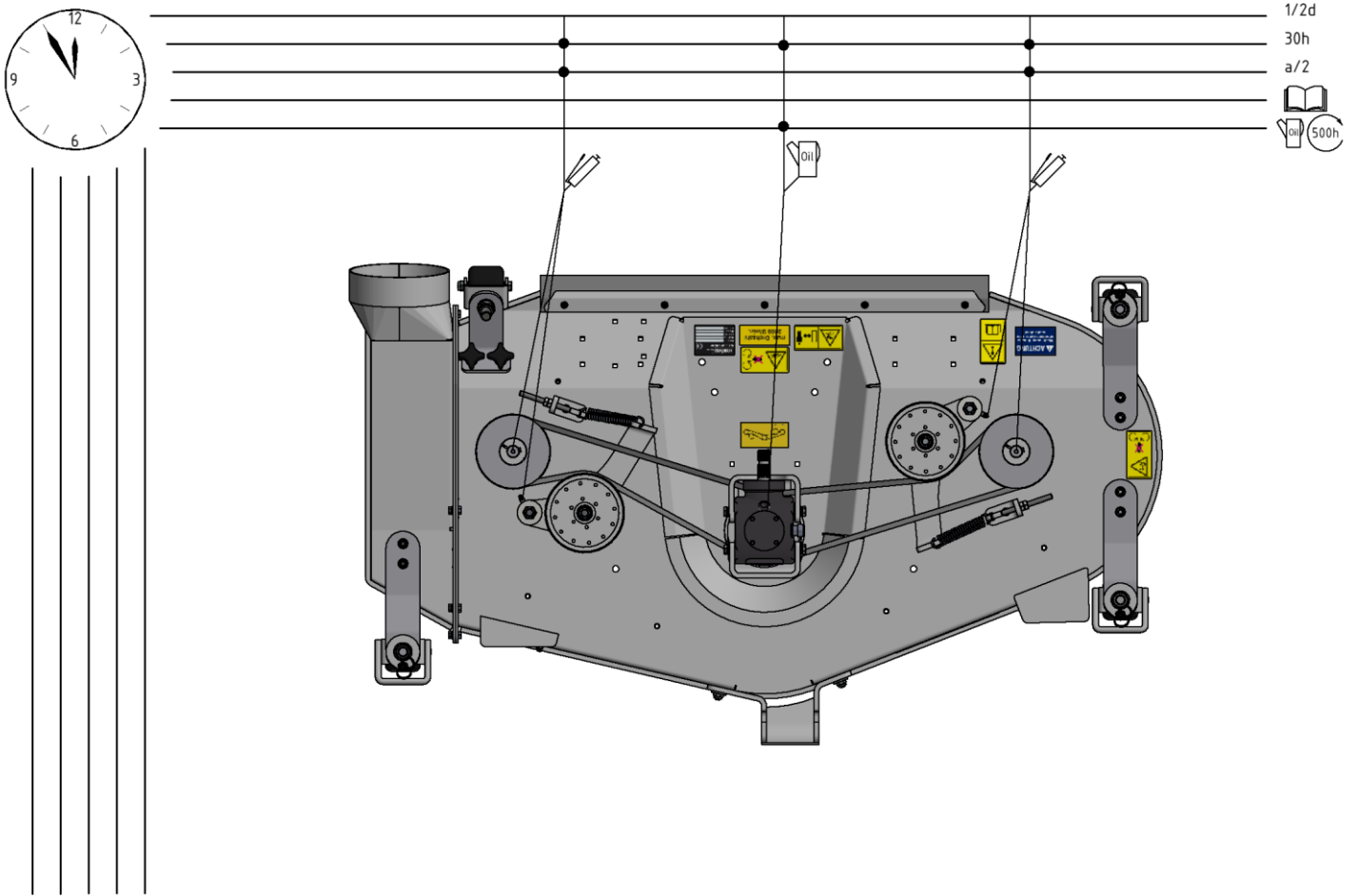

Figure 42 : Maintenance schedule for MOW-MM-152

10.3.2 Maintenance schedule for Boomer 25 hydraulic lift

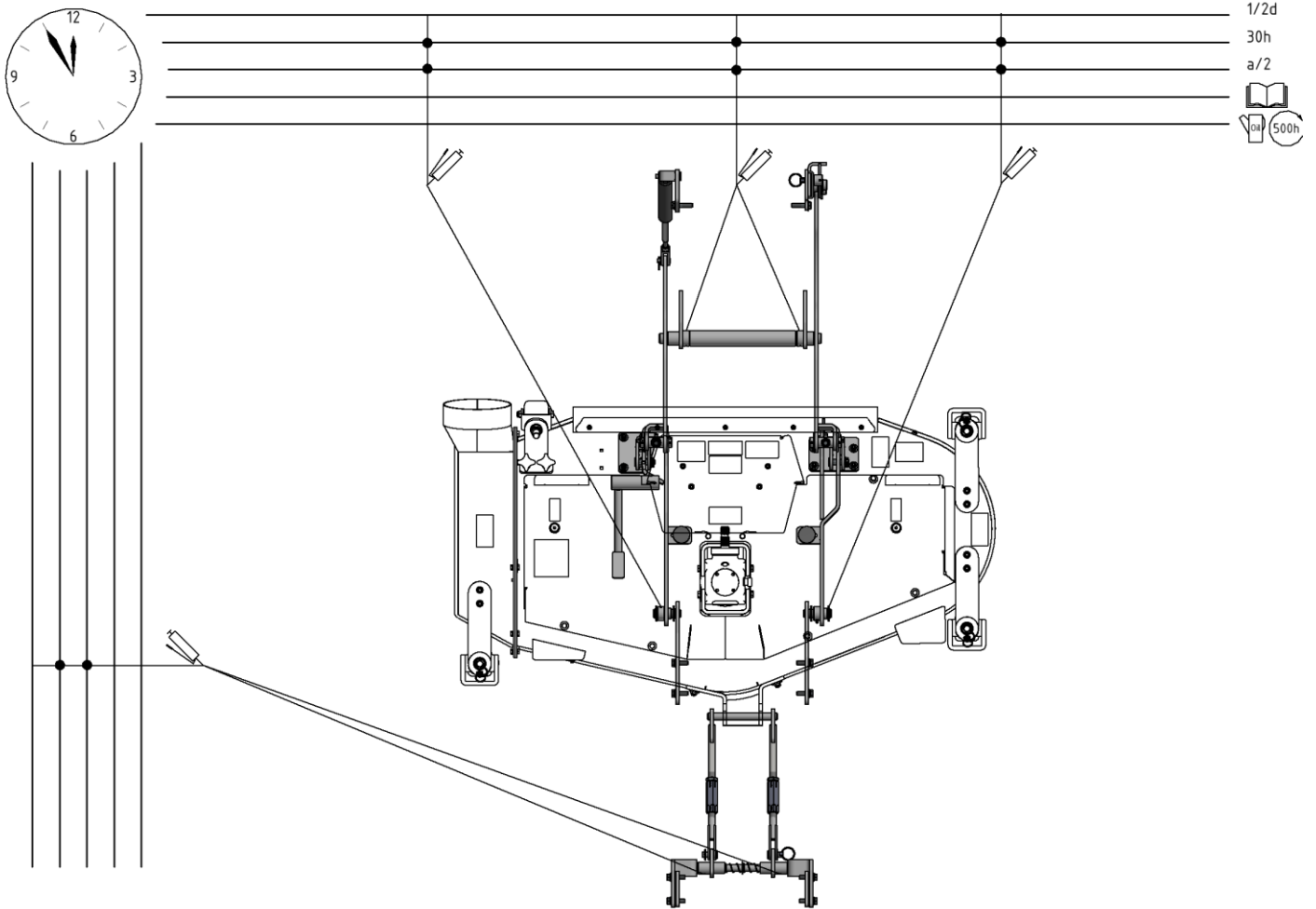

Figure 43 : Maintenance schedule for Kioti CX2510 lift

11 Fault

Fault	Possible cause / correction
Suction hose is clogged	Driving too fast for the given conditions / select an appropriate working speed
Mower does not start up	Excessive clogging in the machine. Immediately switch off, remove the ignition key and clean the entire mowing unit. Lubricate all moving parts.
Poor cutting pattern	<p>Driving too fast for the given conditions. Select an appropriate working speed.</p> <p>Blade dull / sharpen or change blade.</p> <p>Insufficient rpm / drive at full throttle.</p> <p>Blades have seized, e.g. due to grass remnants. Remove blades, clean location, lightly oil blade bearing arrangement and reassemble. It must be possible to easily move the blades.</p> <p>Mower inclination not set correctly. Refer to Figure 38 : Adjust inclination</p> <p>Suction port, suction port Borderless mowing free of grass residues after prolonged mowing or grass that is too wet, the suction port can become clogged.</p>

Table 3 : Fault

12 Repair

If there are faults, problems, or other indications of malfunction, contact your sales consultant or contact the manufacturer directly:

matev GmbH

Nürnberg Str. 50
90579 Langenzenn
Tel.: +49 (0) 9101 9087-0

www.matev.eu

info@matev.eu

Please note the following information as well:

- All repairs must be carried out by a specialized company.
- Use only original matev replacement parts.
- Modifications to the machine are prohibited.

13 Disposal

The implement must be disposed of in accordance with the applicable regulations of the municipality or the country.

Take the parts to the collection points for residual waste, special waste, or recycle them depending on material.

matev GmbH does not provide any disposal services.

The general terms and conditions of matev GmbH apply.

14 Guarantee

The general terms and conditions of matev GmbH apply.

15 List of illustrations

Figure 1 : Definition of orientation and direction of rotation.....	5
Figure 2 : Hydraulic power diagram	7
Figure 3 : Belt drive cover.....	12
Figure 4 : Rear ejection cover	12
Figure 5 : Side ejection cover	13
Figure 6 : Blade cover overview	14
Figure 7 : Safety notice Protection	15
Figure 8 : Safety notice Mower blade.....	15
Figure 9 : Safety notice Read operating manual and retighten screws	16
Figure 10 : Safety notice Drive shaft and belt guide.....	16
Figure 11 : Position of type plate and speed specification	17
Figure 12 : Safety notice Mower blade on cover Mulching or rear ejection	17
Figure 13 : Safety notice Mowing blades and propelling parts on cover Side ejection	18
Figure 14 : Safety notice Mower blade on cover Borderless mowing	18
Figure 15 : Safety notice Mower blade on suction port	19
Figure 16 : Cutting height adjustment	19
Figure 17 : Rear ejection grass flow.....	23
Figure 18 : Mulch insert grass flow.....	24
Figure 19 : Side ejection grass flow	24
Figure 20 : Side ejection with suction port grass flow	25
Figure 21 : Borderless mowing grass flow	25
Figure 22 : Clean the work terrain	26
Figure 23 : Irregular area.....	26
Figure 24 : Mowing large areas	27
Figure 25 : Mowing small areas	27
Figure 26 : Positioning the mower	29
Figure 27 : Drive over mower	30
Figure 28 : Rotate wheel 90°	31
Figure 29 : Push the mower sideways under the tractor	31
Figure 30 : Hanging the front bracket on the mower.....	32
Figure 31 : Connect lift arm to mower	33
Figure 32 : Adjusting the mower on the front bracket	34
Figure 33 : Adjust the mower on the rear suspension.....	35
Figure 34 : Cutting height adjustment	35
Figure 35 : Measuring tool.....	36
Figure 36 : Adjust rear suspension.....	36
Figure 37 : Adjustment screw for cutting height adjustment	37
Figure 38 : Adjust inclination	37
Figure 39 : Adjusting the cutting height	38
Figure 40 : Securing during trips to the site of operation	39
Figure 41 : Belt guide	41
Figure 42 : Maintenance schedule for MOW-MM-152	43
Figure 43 : Maintenance schedule for Kioti CX2510 lift	44

16 List of tables

Table 1 : Technical data	6
Table 2 : Lubrication schedule symbols	42
Table 3 : Fault.....	45